

Traffic Impact Assessment;

75-85 Crown Street and 16 Princess
Highway, St Peters

For C&M Antoniou Pty Ltd

29 November 2024

**parking;
traffic;
civil design;
wayfinding;
ptc.**

Document Control

75-85 Crown Street and 16 Princess Highway, St Peters

Issue	Date	Issue Details	Author	Reviewed	For the attention of
1	02/07/21	Draft	AP	AM	Paul Apostoles
2	07/09/21	Final	AP	AM	Paul Apostoles
3	21/09/21	Final	AP	AM	Paul Apostoles
4	19/07/23	Revised Scheme	AM	AM	Peter Antoniou
5	27/11/24	Final	MA	AM	Peter Antoniou
6	29/11/24	Final	MA	JAJ /AM	Peter Antoniou

Contact

Andrew Morse
+61 2 8920 0800
andrew.morse@ptcconsultants.co

Musstafa Abdullah
+61 2 8920 0800
musstafa.abdullah@ptcconsultants.co

COMMERCIAL IN CONFIDENCE

The information contained in this document, including any intellectual property rights arising from designs developed and documents created, is confidential and proprietary to **ptc.**

This document may only be used by the person/organisation to whom it is addressed for the stated purpose for which it is provided and must not be imparted to or reproduced, in whole or in part, by any third person without the prior written approval of a **ptc.** authorised representative. **ptc.** reserves all legal rights and remedies in relation to any infringement of its rights in respect of its intellectual property and/or confidential information.

© 2023

ptc.
Suite 502, 1 James Place
North Sydney NSW 2060
info@ptcconsultants.co
t + 61 2 8920 0800
ptcconsultants.co

Contents

1.	Introduction	1
1.1	Surrounding Land Use	2
1.2	Authority Requirements	2
2.	Development Proposal	4
3.	Existing Transport Facilities	5
3.1	Road Hierarchy	5
3.2	Road Upgrades	5
3.2.1	Princes Highway	7
3.2.2	Campbell Street	8
3.2.3	Crown Street	9
3.3	Public Transport	9
4.	Parking Requirements	11
4.1	Parking Areas	11
4.2	Car Parking Quantum Requirement	13
4.3	Carshare Parking	14
4.4	Bicycle Parking	14
4.5	Motorcycle Parking	14
4.6	Loading Dock	15
5.	Traffic Generation	16
5.1	Development Traffic Generation	16
5.2	Traffic Distribution	17
5.3	Directional Split	17
6.	Traffic Impact Assessment	19
6.1	Survey Locations	19
6.2	Survey Dates and Items	19
6.3	Survey Data Insights	20
6.4	Modelling Scenarios	20
6.5	Development Traffic Distribution	20
6.6	Intersection Performance Indicators	21
6.7	Assumptions and Limitations	22
6.8	Modelling Results	23
7.	Design Review	25
7.1	Driveway Access	25
7.1.1	Site Distance	25
7.1.2	Pedestrian Sight Lines	25
7.2	Car Park Arrangement	26
7.2.1	Car Parking	26
7.2.2	Headroom Clearance	26
7.2.3	Bicycle Parking	26
7.2.4	Loading Dock	26

8. Conclusion	27
Attachment 1 : Architecture Plan	28
Attachment 2 : SIDRA Analysis	29
Attachment 3 : Swept Paths & Design Commentary	30
Figure 1 – Site Location	1
Figure 2 – Local Land Use Map (Source: NSW Planning Viewer)	2
Figure 3 – Road Classification (Source: NSW Road Network Classifications Map)	5
Figure 4 - Princes Highway / Campbell Street before upgrades (31 October 2016)	6
Figure 5 - Princes Highway / Campbell Street after upgrades (17 June 2021)	6
Figure 6 – Princes Highway Southbound (Source: Google Maps)	7
Figure 7 – Campbell Road North Westbound (Source: Google Maps)	8
Figure 8 – Crown Street Northbound (Source: Google Maps)	9
Figure 9 – Site Location in Proximity to St Peters Train Station (Source: Google Maps)	10
Figure 10 – Marrickville DCP 2011 2.10 - Parking Areas Map	12
Figure 11 – Trip Distribution	17
Figure 12 – Vehicle Directional Splits	18
Figure 13 – Survey Intersection Locations	19
Figure 14 – Existing Traffic Volume	20
Figure 15: Minimum Sight Lines for Pedestrian Safety (Source: AS2890)	25

Table 1 – Authority Requirements	2
Table 2 – Existing Road Network – Princes Highway	7
Table 3 – Existing Road Network – Campbell Street	8
Table 4 – Existing Road Network – Crown Street	9
Table 5 – Car Parking Demand	13
Table 6 – Bicycle Parking Demand	14
Table 7 – Loading Dock and Service Vehicle Demand	15
Table 8 - Development Traffic Generation	16
Table 9 - Level of Service Criteria	22
Table 10 - SIDRA Modelling Results – AM Peak	23
Table 11 - SIDRA Modelling Results – PM Peak	23

1. Introduction

ptc. has been engaged by C&M Antoniou Pty Ltd to prepare a Traffic Impact Assessment to support the proposal associated with the development on the subject site in St Peters. The site comprises the following properties:

- 75 Crown Street, St Peters
- 116 Princes Highway, St Peters
- 85 Crown Street, St Peters

The location of the site is outlined in Figure 1.

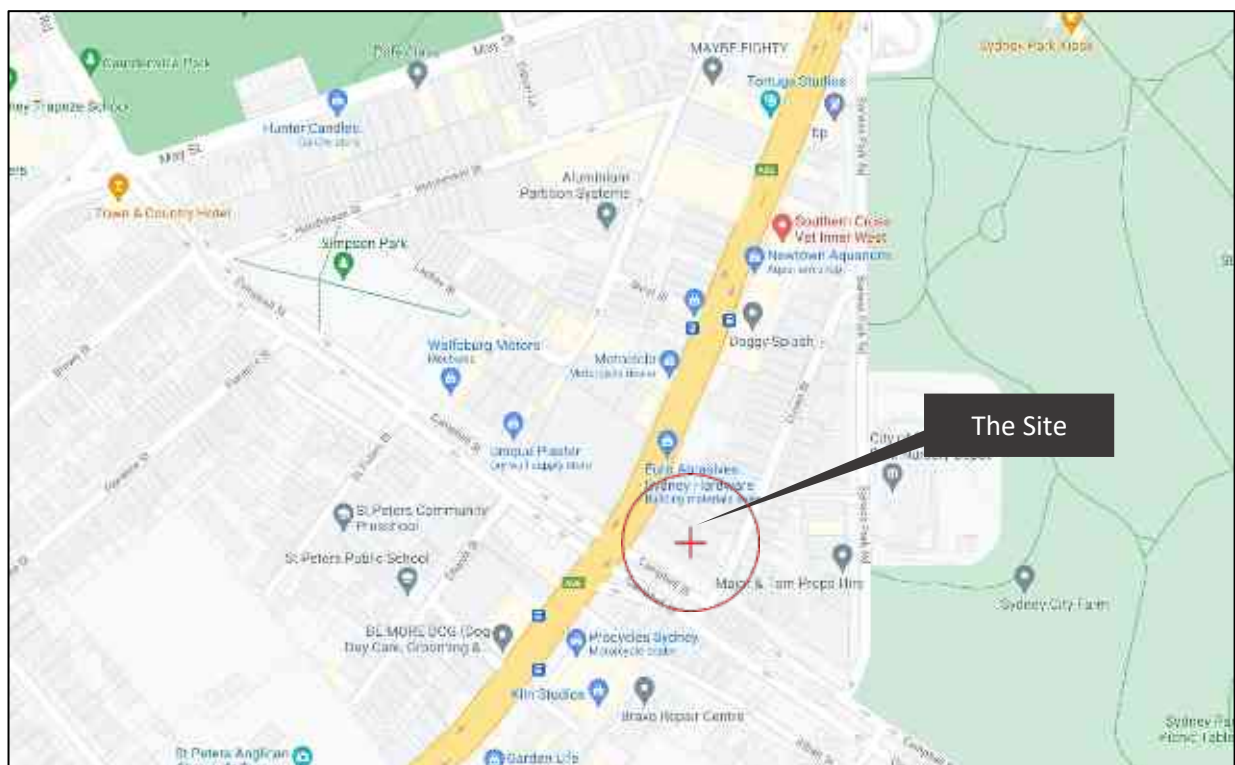

Figure 1 – Site Location

1.1 Surrounding Land Use

The site is an amalgamation of R1 and B4 land zones. The land uses found in the surrounding area are shown in Figure 2

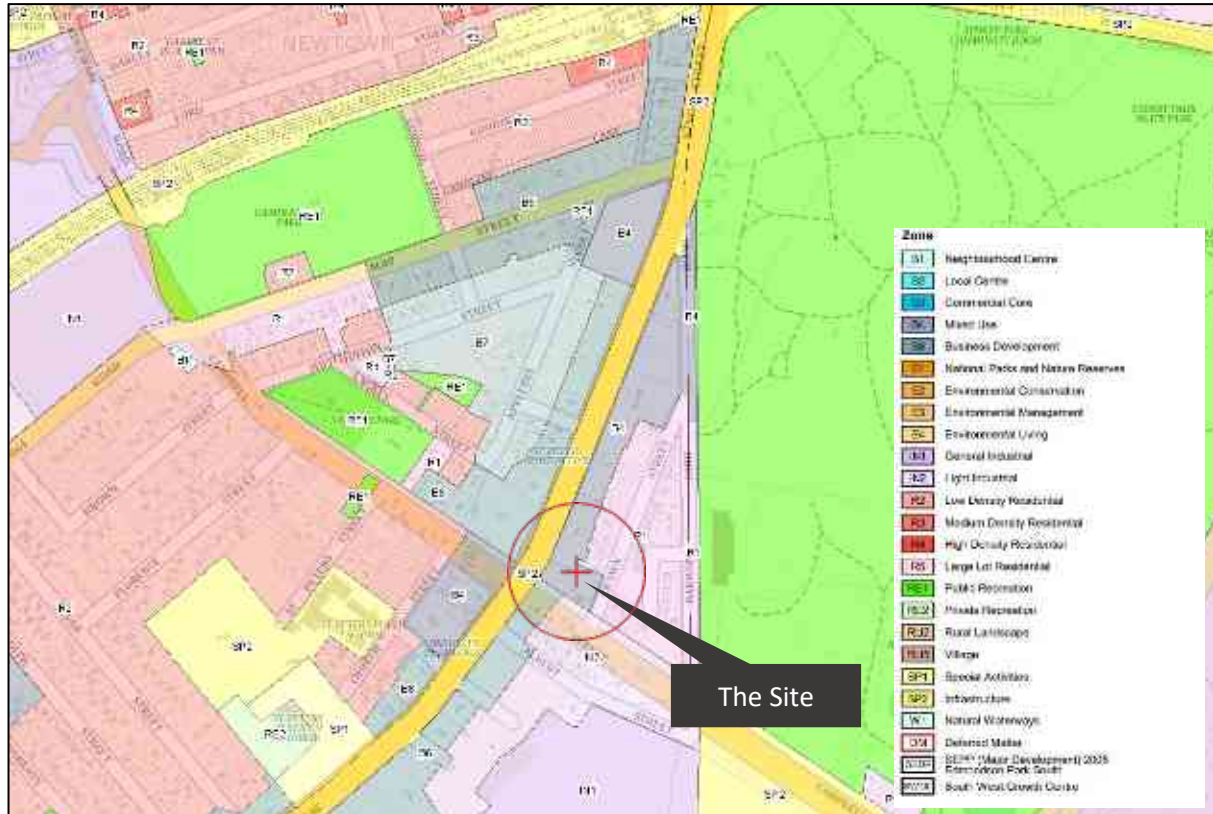

Figure 2 – Local Land Use Map (Source: NSW Planning Viewer)

1.2 Authority Requirements

Following the council meeting on 18 July 2024 regarding the assessment of the planning proposal for the site, several comments were raised concerning traffic and access matters. These comments and their corresponding responses from ptc. are summarized in the table below, along with references to the relevant sections of this report.

Table 1 – Authority Requirements

Comments	ptc.'s Response
Traffic report should be updated to include SIDRA analysis for Princes Highway and Barwon Park Road to assess the existing and proposed delay and queue length for the left and right turns out of Barwon Park Road. The assessment should determine whether any further measures are required to improve safety at the intersection;	Section 6.8 includes a SIDRA analysis for Princes Highway and Barwon Park Road. The right-turn movement poses safety risks, and while delays increase slightly post-development, the Level of Service remains unchanged. It is recommended to ban the right-turn during peak hours to improve safety.
Swept path analysis should provide the road width (kerb to kerb) and any on-street car parking which may interfere with proposed turning manoeuvres;	On-street parking will not be impacted by vehicles turning into and out of the site. Please refer to Attachment 3 for the swept path analysis.

<p>Sight triangles analysis should be undertaken at the entry/exit of the car parking area to ensure safe pedestrian and crossing of the driveway area and vehicle entry and exit;</p>	<p>Sight triangle analysis has been provided at the entry and exit points of the car parking area to ensure safe pedestrian movement and vehicle entry and exit. Refer to Attachment 3 for details.</p>
<p>The design of the vehicular access and car parking facilities must comply with AS/NZS 2890. 1: 2004, AS/NZS 2890. 6: 2009 and AS/NZS 2890. 2: 2018;</p>	<p>The design of the vehicular access and car parking facilities complies with AS/NZS 2890.1:2004, AS/NZS 2890.6:2009, and AS/NZS 2890.2:2018. Further, full compliance will be verified during the Construction Certificate (CC) stage. Refer to Section 7 and Attachment 3</p>
<p>To allow vehicle drivers adequate visibility to pedestrians on the footpath the driveway and ramps must be designed so that the maximum grade does not exceed 1 in 20 (5%) within 6m of the property boundary as required by Clause 3.3(a) of AS2890.1-2004 and Control C9 of Marrickville DCP 2011 Part 2.10 Parking Management;</p>	<p>The vehicular access has been designed to in accordance with 2890 series. Full compliance shall also be verified during the CC stage.</p>
<p>The vehicular access must be designed to provide clear sight lines (triangles) to pedestrians in accordance with the requirements of Clause 3.2.4(b) of AS/NZS 2890.1-2004;</p>	<p>The vehicular access has been designed to provide clear sight lines (triangles) to pedestrians in accordance with the requirements of Clause 3.2.4(b) of AS/NZS 2890.1:2004. Full compliance will also be verified during the CC stage.</p>
<p>Turntables are generally not supported due to problems with reliability and maintenance. The loading dock must be redesigned such that all vehicular movements to and from the site are in a forward direction without the use of a turntable. It shall also be designed to fully accommodate Council's Waste Vehicle for on-site collection;</p>	<p>The swept path analysis indicates that there is sufficient space to perform a three-point turn without the use of a turntable. Refer to Attachment 3 for details.</p>
<p>Splay corners shall be provided at the intersection to improve sight distance and to improve the amenity of pedestrians at the intersections. The minimum splays shall be 3mx3m;</p>	<p>Splay is provided. Refer to the architecture plan</p>
<p>Reduce car parking provision should be considered in the draft DCP given the site's location in close proximity to public and active transport. The draft DCP should also incentivize active transport by including appropriate provision for end-of-trip facilities.</p>	<p>Car parking has been provided with consideration for the site's location and its proximity to public and active transport options. Refer to Section 4.2 for further details.</p>

2. Development Proposal

The rezoning request is accompanied by an indicative design scheme by Studio SC Architects which shows:

- Demolition of existing structures
- A mixed-use development with:
 - Two basement levels accessed from Crown Street incorporating 44 car parking spaces, end of trip facilities and plant
 - A ten-storey building composed of 8 residential levels above two commercial floor levels (retail, and office)
 - A three storey plus mezzanine building component facing Crown Street
 - A four-storey street wall to Princes Highway
 - A maximum building height of RL 51 to the top of the lift overrun
 - Gross floor area equal to 9,408 square metres
 - A total of 82 apartments (8 x studio, 27 x 1 bedroom, 28 x 2-bedroom, 19 x 3 bedroom)
 - Common open space areas at levels 1, 2 and 4 with provision for integrated landscaping and 15% canopy tree cover
 - A residential lobby to Campbell Street
 - A loading dock, additional car parking, EOT facilities and waste room at ground floor level
 - Deep soil zones along Campbell and Crown Streets
 - Integration of public art into the south façade and materiality that references the industrial heritage of the area.

3. Existing Transport Facilities

3.1 Road Hierarchy

The site fronts Princes Highway and Campbell Street which are classified as state and regional roads respectively. The surrounding roads and their road classifications are shown in Figure 3.



Figure 3 – Road Classification (Source: NSW Road Network Classifications Map)

The NSW administrative road hierarchy comprises the following road classifications, which align with the generic road hierarchy:

- State Roads: Freeways and Primary Arterials (RMS Managed);
- Regional Roads: Secondary or sub-arterials (Council Managed, Part funded by the State);
- Local Roads: Collector and local access roads (Council Managed).

Details of the roads in the vicinity of the site are provided in the following section.

3.2 Road Upgrades

The road network in the vicinity of the site has recently undergone a significant upgrade as part of the Westconnex project. Works relevant to the site include the widening of Campbell Street from one lane in each direction to six lanes to the east of the Princes Highway.

The intersection of the Highway and Campbell Street has been significantly upgraded and now accommodates dedicated right turn lanes on all approaches.

Given the recent completion of these works, the risk of further widening works is low and the road network has increased capacity to accommodate the low traffic activity generated by the development.



Figure 4 - Princes Highway / Campbell Street before upgrades (31 October 2016)



Figure 5 - Princes Highway / Campbell Street after upgrades (17 June 2021)

3.2.1 Princes Highway

Table 2 – Existing Road Network – Princes Highway

Princes Highway	
Road Classification	State Road
Alignment	North-South
Number of Lanes	3 lanes in each direction
Carriageway Type	Divided
Carriageway Width	~18m
Speed Limit	60 km/h
School Zone	No
Parking Controls	Clearway 6am-10am Northbound, Clearway 3pm – 7pm Southbound
Forms Site Frontage	Yes



Figure 6 – Princes Highway Southbound (Source: Google Maps)

3.2.2 Campbell Street

Table 3 – Existing Road Network – Campbell Street

Campbell Street	
Road Classification	Regional Road
Alignment	Northwest - Southeast
Number of Lanes	3 lanes in each direction east of Princes Highway 2 lanes in each direction west of Princes Highway
Carriageway Type	Divided
Carriageway Width	~17-25m
Speed Limit	60 km/h east of Princes Highway 50 km/h west of Princes Highway
School Zone	No
Parking Controls	Clearway 6am-10am Northbound, Clearway 3pm – 7pm Southbound
Forms Site Frontage	Yes



Figure 7 – Campbell Road North Westbound (Source: Google Maps)

3.2.3 Crown Street

Table 4 – Existing Road Network – Crown Street

Crown Street	
Road Classification	Local Road
Alignment	North – South
Number of Lanes	1 lane northbound
Carriageway Type	Single lane road
Carriageway Width	~6m
Speed Limit	50km/h (unposted)
School Zone	No
Parking Controls	2P 8:30am – 6pm Mon - Fri
Forms Site Frontage	Yes



Figure 8 – Crown Street Northbound (Source: Google Maps)

3.3 Public Transport

The site is well-serviced by public transport, with a particular advantage being its proximity to St Peters Train Station, located approximately 650m from the development. St Peters Station is a significant transport hub on the Sydney Trains network, providing access to the T8 Airport & South Line. This line offers frequent services connecting the site to key destinations, including Sydney CBD, the airport, and surrounding suburbs, facilitating convenient access for residents, employees, and visitors.

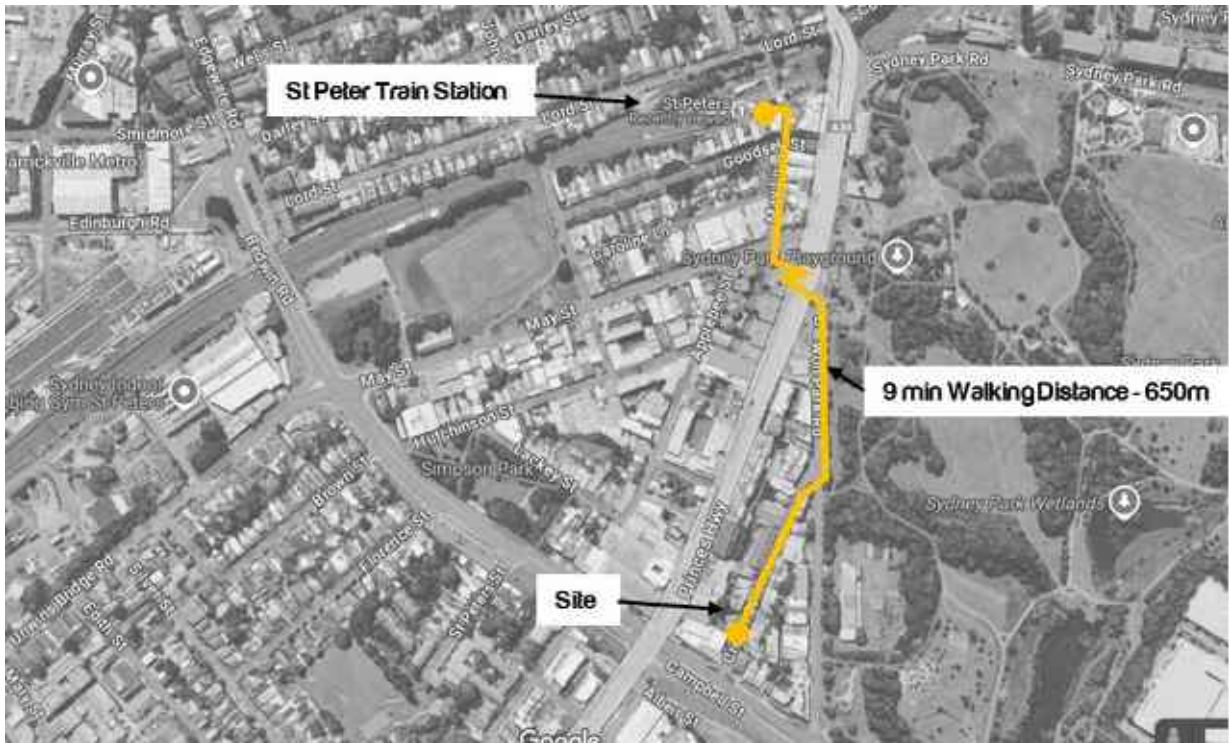

Figure 9 – Site Location in Proximity to St Peters Train Station (Source: Google Maps)

4. Parking Requirements

4.1 Parking Areas

The Inner West Council DCP for the former Marrickville LGA provides car parking rates based on the area in which the site is located. Each lot has been categorised in one of three parking areas. There are:

- Parking Area 1, where car parking is most constrained, is defined as:
 - The suburb of Newtown, but excluding land to the west of Edgeware Road;
 - The suburb of Camperdown, but excluding land to the north of Salisbury Road, to the west of St Marys Street, to the north of Trade Street and to the west of Kingston Road;
 - The suburb of Enmore, but excluding land to the west of Liberty Street, to the south of Stanmore Road and to the west of Enmore Road;
 - 200 metres around railway stations; and
 - All business zones within the major centres of Marrickville, Dulwich Hill and Petersham.
- Parking Area 2, where parking is moderately constrained, is defined as:
 - 200 metres around Parking Area 1;
 - 200 metres around light rail stops and Strategic Bus Corridor routes; and
 - All business zones not within Parking Area 1.
- Parking Area 3, where car parking is least constrained, is defined as:
 - All land not within Parking Area 1 or Parking Area 2.

The site spans across both Parking Areas 2 and 3 with the majority of the site located on Parking Area 2 as illustrated overleaf.



Figure 10 – Marrickville DCP 2011 2.10 - Parking Areas Map

4.2 Car Parking Quantum Requirement

The proposed development is located on lots categorised under Parking Area 2 and partially Parking Area 3 (75 Crown Street), with applicable parking rates outlined in Table 1 of the Marrickville Development Control Plan (DCP) 2011. These rates, shown in Table 5, have been used to calculate parking demand for the residential, commercial, and retail components of the development.

Table 5 – Car Parking Demand

Land Use	Quantum	Parking Rate		Parking Demand	
		Area 2	Area 3	Area 2	Area 3
Studio	8 units	0.4 per unit	0.6 per unit	3.2	4.8
1-Bed Unit	27 units	0.5 per unit	0.8 per unit	13.5	21.6
2-Bed Unit	28 units	1 per unit	1.2 per unit	28	33.6
3-Bed Unit	19 units	1.2 per unit	1.2 per unit	22.8	22.8
Visitors	82 units	0.1 per unit	0.1 per unit	8.2	8.2
Adaptable Units	0 units	1 per unit	1 per unit	0	0
Adaptable Units Visitors	0 units	0.25 per unit	0.25 per unit	0	0
Residential Sub Total				76 (75.7)	91
Commercial	1,016m ² GFA	1 per 80m ² GFA	1 per 50m ² GFA	13 (12.7)	20 (20.3)
Retail	79m ² GFA	1 per 80m ² GFA	1 per 50m ² GFA	1 (0.98)	2 (1.6)
Non-Residential Sub Total				14	22
Total				90	113

The Marrickville DCP in Section 2.1 emphasises the Accessible Development Principles outlined in the Integrating Land Use and Transport Policy. Principle 8, which focuses on managing parking supply, advocates for reducing parking in areas well-served by public transport to discourage car dependency and promote sustainable transport. Specifically, the objective states:

“To use the location, supply, and availability of parking to discourage car use. Prominent, plentiful, cheap, and unrestricted parking encourages people to drive; public transport becomes a less attractive alternative.”

The principle further highlights the importance of aligning parking policies with broader land use and transport strategies, emphasising that:

“Provision and management of parking is related to land use, with maximum provision rates identified.”

The development proposes a total of 44 car spaces, which is deemed acceptable to the development when considering the surrounding public and active transport options.

The site's location approximately 650m from St Peters Train Station (refer to section 3.3), enhancing its accessibility by public transport.

Council has suggested reducing parking provision in recognition of the site's proximity to public transport and has encouraged the inclusion of end-of-trip facilities and bicycle parking to incentivise active transport. The proposed parking provision aligns with these recommendations, supporting the DCP's broader objectives to manage parking effectively and encourage sustainable travel behaviour.

4.3 Carshare Parking

Carshare schemes provide an alternative means by which residents and business operators can have access to a car, and as such, may enable on-site parking for private cars to be reduced from the rates specified in car parking provision in Table 1 of the DCP.

4.4 Bicycle Parking

In contrast to car parking, bicycle parking provision rates are uniformly applied across the LGA and are generally applied to meet current unconstrained demand and a modest level of growth in bicycle ownership/use in the future.

The following parking rates extracted from Table 5 of the Marrickville DCP 2011 apply:

Table 6 – Bicycle Parking Demand

Land Use	Quantum	Bicycle Parking Rate	Bicycle Parking Demand
Residential Flat Buildings	82 units	1 per 2 units	41
Visitors	82 units	1 per 10 units	8
Commercial / Retail	1,095m ² GFA	1 per 300m ² for staff	4
Total			53

Further to the above, clothes lockers are to be provided at a rate of 1 per 3 staff spaces for commercial and retail which is a total of 3 lockers.

The bicycle parking spaces should be in secure locations for staff and residents usually in the form of lockers or racks in secure basement car parks. The architectural drawings indicate a room within the Ground floor adjacent to the lift core and within Basement 1, which should be sufficient to accommodate the end-of-trip and bike parking requirements for residents and staff.

For customers and visitors, the bicycle parking should be located near building entrances or on the street.

4.5 Motorcycle Parking

The DCP requires that motorcycle parking be provided at a rate of 5% of the car parking rounded to the nearest whole number. Based on the 44 parking spaces, this is 2 motorcycle spaces. There is sufficient area within the basement to accommodate 2 motorcycle spaces in areas that are not identified for other purposes.

4.6 Loading Dock

The following rates for service and deliver vehicle areas are required:

Table 7 – Loading Dock and Service Vehicle Demand

Land Use	Quantum	Loading / Servicing Rate	Loading / Servicing Demand
Residential flat buildings and residential components of mixed-use developments	82units	One service vehicle space per 50 apartments (above first 50) up to 200 apartments plus one space per 100 apartments thereafter.	1.74
Commercial / Retail	1,095m ² GFA	one truck space per 4000m ² GFA up to 20000m ² GFA plus one truck space per 1000m ² thereafter (50% spaces adequate for trucks).	0.25

According to the above, the development will need to provide one loading dock space that can accommodate a truck (to be shared between the industrial and commercial land uses) and two service vehicle spaces for the residential flat land use. The two service vehicle spaces for the residential land use can include spaces provided for B99 vehicles.

The architectural drawings include a loading dock for a single commercial vehicle (an 8.8m long MRV), through the use of a turntable while two parking spaces adjacent to the basement access ramp could be dedicated to the B99 service vehicles.

5. Traffic Generation

5.1 Development Traffic Generation

The proposed development consists of residential flats, a light industrial space and a café. The rates and development trip generations are summarised in Table 8. The rates applied for residential, commercial, and retail land uses were sourced from the Guide to Traffic Impact Assessment (GTIA), while the rates for light industrial were derived from the RTA Guide.

Table 8 - Development Traffic Generation

Land Use	Peak Hour	Quantum	Trip Generation Rate	Generated Trips / Hour
Residential	AM	82 units	0.39 per unit	32
	PM		0.37 per unit	30
Commercial	AM	1,016m ² GFA	1.69 per 100m ²	17
	PM		1.20 per 100m ²	12
Retail	AM	79m ² GFA	1.78 per 100m ²	1
	PM		3.71 per 100m ²	3
Total	AM			50
	PM			45

The proposed development is expected to generate 45 - 50 vehicle trips per hour during the AM and PM peak hours. These are considered low trip generation numbers and are not anticipated to significantly impact the performance of the existing road network, particularly given the recent large-scale road upgrades in the area.

Furthermore, as the site is a brownfield development, the trips generated by the existing land use should be discounted from the total trips associated with the proposed development. This effectively reduces the net increase in traffic attributable to the new development. However, for a conservative assessment, the development traffic generation will be used in the SIDRA analysis.

5.2 Traffic Distribution

The traffic distribution of the proposed development was assumed to be as follow:

- AM Peak: 20% Inbound and 80% Outbound
- PM Peak: 80% Inbound and 20% Outbound



Figure 11 – Trip Distribution

5.3 Directional Split

The directional split and travel routes have been analysed based on the surrounding road rules (such as one-way streets) and the strategic location of nearby business hubs and major arterial roads, as illustrated in Figure 12.

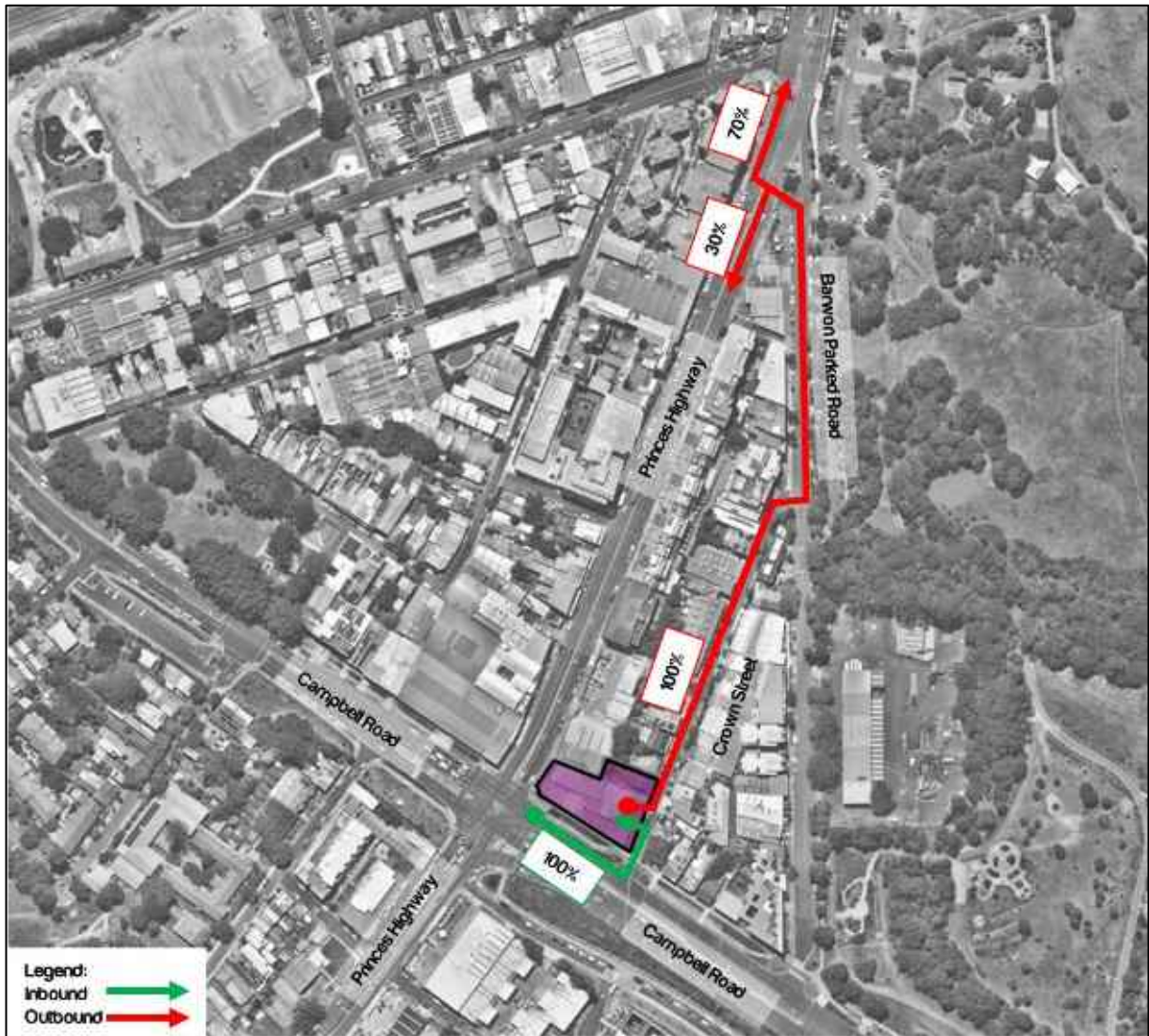

Figure 12 – Vehicle Directional Splits

6. Traffic Impact Assessment

6.1 Survey Locations

The following intersections have been surveyed, an overview of the intersection locations in relation to the Project site is illustrated in

- Princes Highway / Barwon Park Road

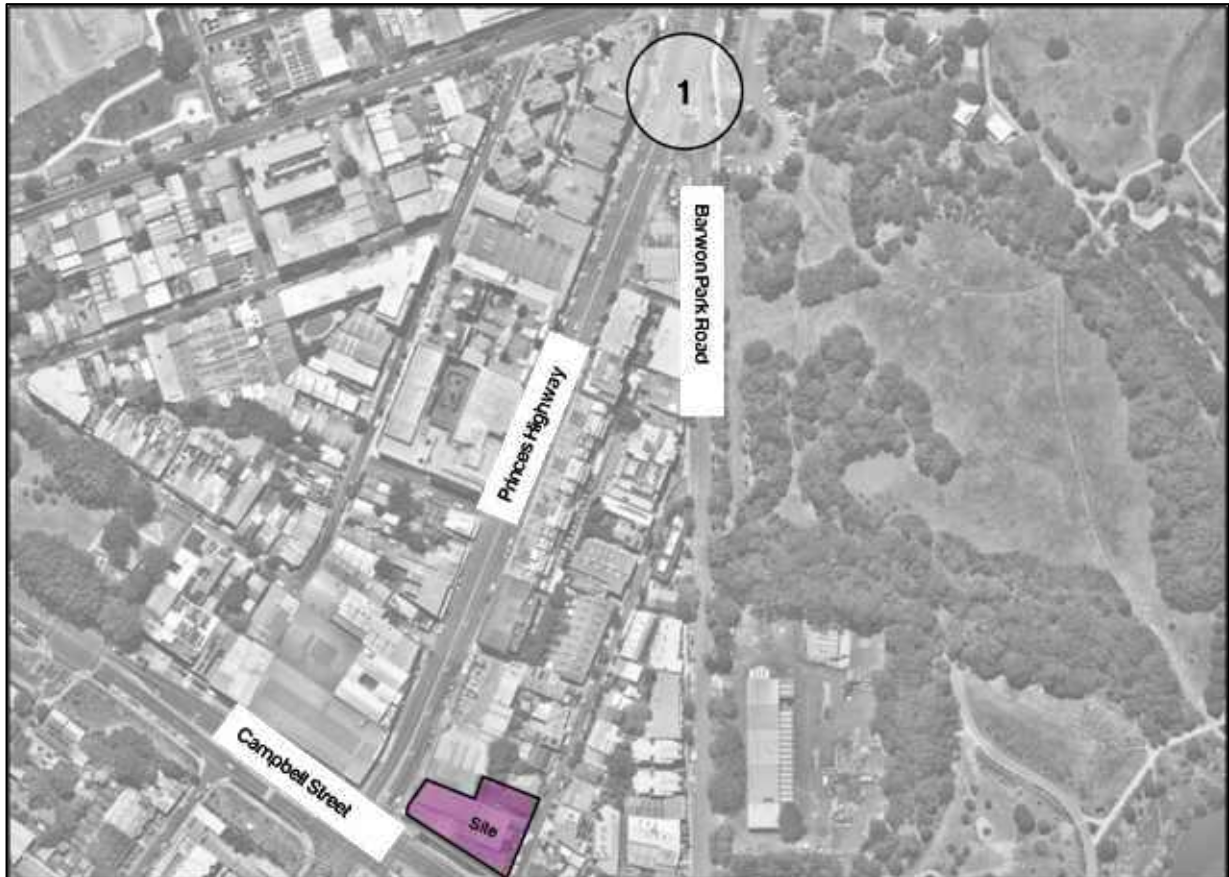

Figure 13 – Survey Intersection Locations

6.2 Survey Dates and Items

A typical weekday which are outside of school holidays, have been surveyed to understand the typical traffic activity in the area. The dates selected for the survey are:

- Thursday 14 November 2024

The following items have been obtained:

- Traffic counts: classified in light vehicles, heavy vehicles, buses, cyclists, and pedestrians.

The survey items provide crucial data for the intersection modelling required in the scope of the Project.

6.3 Survey Data Insights

From the intersection survey data, the following network peak hour, which counts the highest number of traffic volumes, has been identified:

- AM Peak: 8:00am - 9:00am
- PM Peak: 5:00pm – 6:00pm

The traffic volumes during the network peak hour are used for the intersection modelling, as it reflects the busiest hour and is able to model a “worst-case” scenario. The existing traffic volume for the surrounding intersections in AM and PM peak are show in Figure 14.

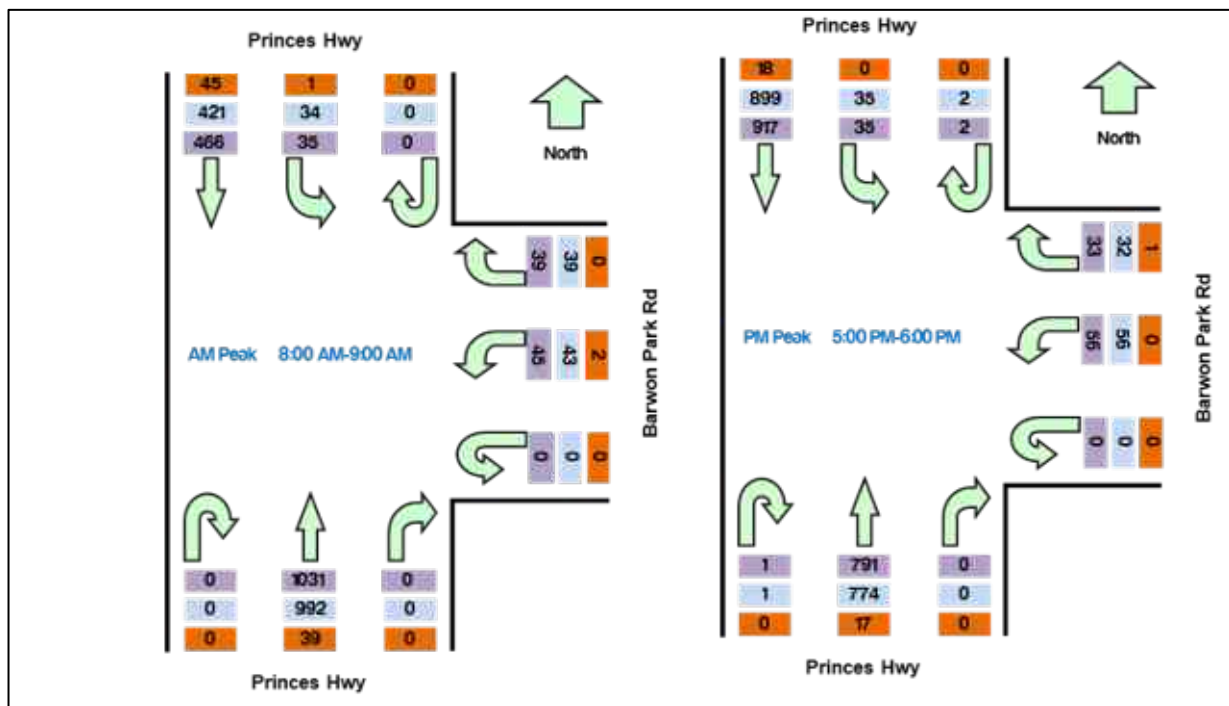

Figure 14 – Existing Traffic Volume

6.4 Modelling Scenarios

Three scenarios have been modelled to assess the network around the project site, they are:

- Base model: the existing weekday AM and PM
- Post-development Model: the base weekday AM and PM with the proposed development traffic.

6.5 Development Traffic Distribution

Considering the study and analysis of the location, transport network and facilities of the project, combined with the proposed access arrangement of the proposed, it is estimated that during the AM peak period, 20% of the total trips will consist of inbound traffic to the site, while 80% will be outbound. Conversely, during the PM peak period, it is anticipated that 80% of the total trips will be inbound to the site, with 20% being outbound.

6.6 Intersection Performance Indicators

In SIDRA Modelling, typically there are four performance indicators summarising the performance of an intersection, being:

- **Average Delay:** the average delay encountered by all vehicles passing through the intersection. It is often important to review the average delay of each approach as a side road could have a long delay time, while the large free flowing major traffic will provide an overall low average delay.
- **Degree of Saturation (DoS):** the total usage of the intersection expressed as a factor of 1 with 1 representing 100% use/saturation (e.g., 0.8=80% saturation).
- **95% Queue lengths (Q95):** defined to be the queue length in metres that has only a 5-percent probability of being exceeded during the analysis time period. It transforms the average delay into measurable distance units.
- **Level of Service (LoS):** a categorisation of average delay, intended for simple reference. TfNSW adopts the following bands:

Table 9 - Level of Service Criteria

Level of Service	Average Delay (secs/veh)	Traffic Signals, Roundabout	Give Way & Stop Signs
A	<14	Good operation	
B	15 to 28	Good with acceptable delays & spare capacity	Acceptable delays & spare capacity
C	29 to 42	Satisfactory	Satisfactory, but accident study required
D	43 to 56	Operating near capacity	Near capacity & accident study required
E	57 to 70	At capacity. At signals, incidents would cause excessive delays. Roundabouts require other control mode	At capacity, requires other control mode
F	>70	Extra capacity required	Extreme delay, major treatment required

6.7 Assumptions and Limitations

All source data employed in preparing the traffic and transport assessment has been reviewed by **ptc.** with respect to its quality. However, given the level of detail of the assessment and the reliance on assumptions, the accuracy of modelling predictions will be influenced by unknown and unexpected changes to what has been assumed to occur in the future.

ptc. has applied the appropriate effort and attention to ensure the completeness and accuracy of the analysis included in this report. The traffic assessment documented within this report has been undertaken based on the following assumptions.

- Nemap was utilised for SIDRA base model geometry coding, which is assumed to be reflective of the current traffic network
- Surveyed intersection turning counts (2024) have been applied for base year traffic demand development
- Surveyed queue length data (2024) has been utilised for base year SIDRA model calibration purpose
- Surveyed video footage was utilised for the base year SIDRA model delay validation purposes
- The traffic model development process and results based on Roads and Maritime’s Traffic Modelling Guidelines (2013).
- The Critical Gap and Follow-Up Headway for the right turn from Barwon Park Road into Princes Highway were set to 7 seconds and 4 seconds, respectively. These values were based on video observations from the traffic survey and aligned with the Traffic Modelling Guidelines (2013).
- For the left turn, the Critical Gap and Follow-Up Headway were set to 5 seconds and 3 seconds, respectively, reflecting typical driver behaviour and observed conditions.
- The Extra Bunching value was set to 20% for the south approach and 25% for the north approach, in accordance with the SIDRA Intersection User Guide.
- The development traffic generation outlined in Table 8 is used for a conservative assessment.
- The traffic distribution and the directional split outlined in Section 5.2 and Section 5.3 were used in the analysis.

6.8 Modelling Results

Results for all intersections and the comparison between the three scenarios can be found Table 10 and Table 11 the full SIDRA modelling results are in Attachment 1.

Table 10 - SIDRA Modelling Results – AM Peak

Intersection	Scenarios	LoS	Delay (s) ¹	Highest DoS (v/s)	Highest Q95 (m)	Average Queue Length (m)
Princes Highway / Barwon Park Road	Base model	LOS E	69.7	0.538	22.2	9
	Post-Development	LOS F	120.3	0.906	71	28

Table 11 - SIDRA Modelling Results – PM Peak

Intersection	Scenarios	LoS	Delay (s) ²	Highest DoS (v/s)	Highest Q95 (m)	Average Queue Length (m)
Princes Highway / Barwon Park Road	Base model	LOS F	112.9	0.747	28.2	11.3
	Post-Development	Los F	131.8	0.868	42.2	17

The SIDRA analysis highlights the critical performance measures for the intersection of Princes Highway and Barwon Park Road, focusing on the worst-performing movement: the right turn from Barwon Park Road onto Princes Highway. This movement requires vehicles to cross six lanes of traffic (three in each direction), presenting safety risks and operational challenges.

The queue length analysis reveals that while the 95th percentile queue length provides a worst-case scenario, the average queue length offers a more realistic reflection of typical conditions. For the AM peak, the base model shows a 95th percentile queue length of 22.2 meters and an average queue length of 9 meters. Post-development, these figures increase to 71 meters and 28 meters, respectively. Similarly, in the PM peak, the 95th percentile queue length rises from 28.2 meters in the base case to 42.2 meters post-development, while the average queue length grows from 11.3 meters to 17 meters. It is important to note that the average queue lengths align more closely with what was observed on-site, suggesting that the 95th percentile values represent infrequent but possible extremes.

The safety risks associated with the right-turn movement are exacerbated by the need to cross multiple traffic lanes, increasing the likelihood of conflicts, especially during peak periods. Although the development contributes additional traffic, the intersection’s LOS remains within LOS E and F under both base and post-development scenarios, indicating that the development will not significantly worsen existing conditions.

Given the safety concerns and the SIDRA findings, it is recommended to ban the right-turn movement from Barwon Park Road onto Princes Highway during peak hours. This will discourage unsafe turning manoeuvres and redirect traffic to safer alternative routes, such as turning left onto Princes Highway, then right onto Campbell Street, right

¹ Delay of the most critical turn movement has been considered.

² Delay of the most critical turn movement has been considered.

onto May Street, and finally left onto Princes Highway. This recommendation aims to improve safety while maintaining efficient traffic operations.

7. Design Review

7.1 Driveway Access

Vehicular access to the site is provided via Crown Street, consistent with TfNSW and Council guidelines for utilising the lowest order road. The driveway is designed as a shared access point for both light and heavy vehicles. The driveway has been designed to accommodate an 8.8m Medium Rigid Vehicle (MRV), which can safely access the site through this entry point

7.1.1 Site Distance

The sight distance requirements are outlined in Section 3.2 of AS2890.1 and are prescribed on the basis of the posted speed limit or 85th percentile vehicle speeds along the frontage road.

Crown Street has an unposted speed limit of 50km/h, which requires a desirable visibility distance of 69 metres and a minimum stopping sight distance of 45 metres. The proposed driveway is located approximately 40m from the intersection of Campbell Road and Crown Street. It is noted that due to the proximity to the intersection and the bicycle and pedestrian priority crossing along Crown Street immediate after motorists turn from Campbell Street onto Crown Street in conjunction with the road being a narrow one-way road, the vehicles will not be capable of achieving 50km/h at the site access. Hence, the sight distance required at the access will be much less.

The proposed car park also allows for all vehicles to enter and exit in a forward direction, therefore minimising potential conflict points and maintaining the overall safety of the road network.

7.1.2 Pedestrian Sight Lines

AS2890 requires that clear sight triangles shall be provided at the property line to ensure adequate visibility between exiting vehicles and pedestrians on the frontage road footpath.

The pedestrian sight triangles associated with the entry of the proposed development on the ground floor on Crown Street, have been reviewed and are found to be compliant with AS2890.

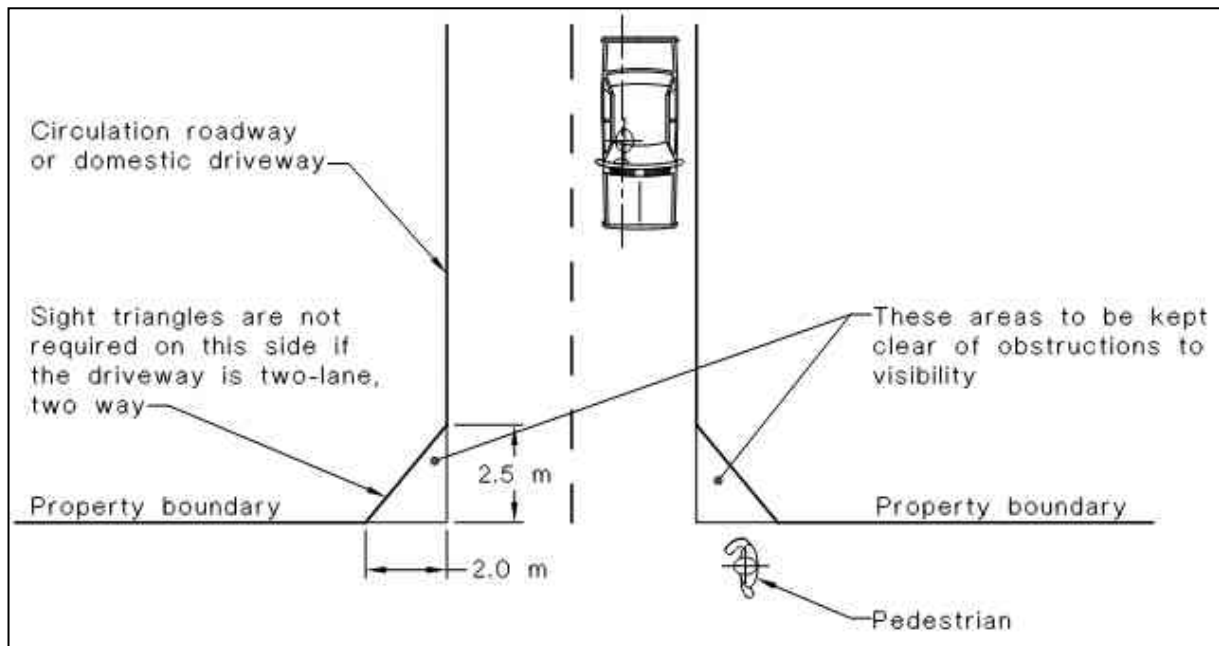

Figure 15: Minimum Sight Lines for Pedestrian Safety (Source: AS2890)

7.2 Car Park Arrangement

7.2.1 Car Parking

The car parking must comply with AS2890.1:2004, with reference to Class 1A (residential/employees) facilities:

Class 1A (residential/employee) facilities:

- Car Space Dimensions: 2.4m x 5.4m
- Aisle Width: 5.8m (double-sided aisles)

7.2.2 Headroom Clearance

The following are the requirements stipulated in the Australian Standards:

- Minimum 2.2m above all general spaces;
- Minimum 2.5m above all accessible spaces and adjacent shared bays;
- Wherever access is required by 8.8m MRVs, a minimum clear headroom of 4.5m shall be provided (i.e. within the loading dock and along the entire vehicle access path). This clear headroom is to be measured to the underside of any overhead obstructions including, but not limited to, utilities, mechanical ducts, sprinklers, lighting or any other overhead fixtures, etc.)

The proposed car park is to provide the minimum height clearance as per the requirements stipulated in the Australian Standards.

7.2.3 Bicycle Parking

Approved bicycle parking devices (BPD's) shall be installed as per the following requirements of AS2890.3:2015:

Horizontal Bicycle Parking

- Space Dimensions: 1800mm x 500mm
- Access Aisle 1500mm

As mentioned previously, the bicycle spaces for staff and residents are to be provided in a secure location usually in the basement car park.

7.2.4 Loading Dock

The loading dock is designed to accommodate the largest design vehicles, ensuring they can enter and exit the site in a forward direction. An 8.8m Medium Rigid Vehicle (MRV) will perform a 3-point turn within the site to get into the loading dock. Swept path analysis, provided in Attachment 3, demonstrates that the required turning movements can be completed safely and efficiently within the available space.

8. Conclusion

ptc. has been commissioned by C & M Antoniou to undertake a Traffic Impact Assessment for the proposed development at 75-85 Crown Street and 16 Princess Highway, St Peters.

The findings of this report can be summarised as follows:

- The development is anticipated to generate approximately 50 trips in the morning peak hour and 45 trips in the evening peak hour, which will have no perceptible impact on the operation of the surrounding road network, which has undergone significant upgrades and capacity increases associated with the Westconnex project.
- The development is proposed to provide a total of 44 car parking spaces.
- Car share may be used in the development to supplement parking provisions.
- Motorcycle spaces should be provided at a rate of 5% of car parking spaces.
- Site access is designed in accordance with AS 2890.2 and allow for the access for the largest design vehicle (assumed to be MRV).
- Car parking is designed in accordance with AS 2890.1 and the current drawings.
- Based on our initial assessment, the development is unlikely to significantly impact the surrounding road network.

Attachment 1 : Architecture Plan

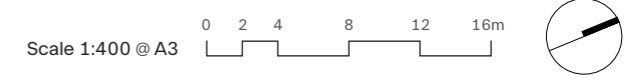

Legend

- Studio
- 1 Bed
- 2 Bed, 2 Bath
- 2 Bed, 1 Bath
- 3 Bed
- Common
- Industrial/Commercial
- Retail/Cafe
- Landscape

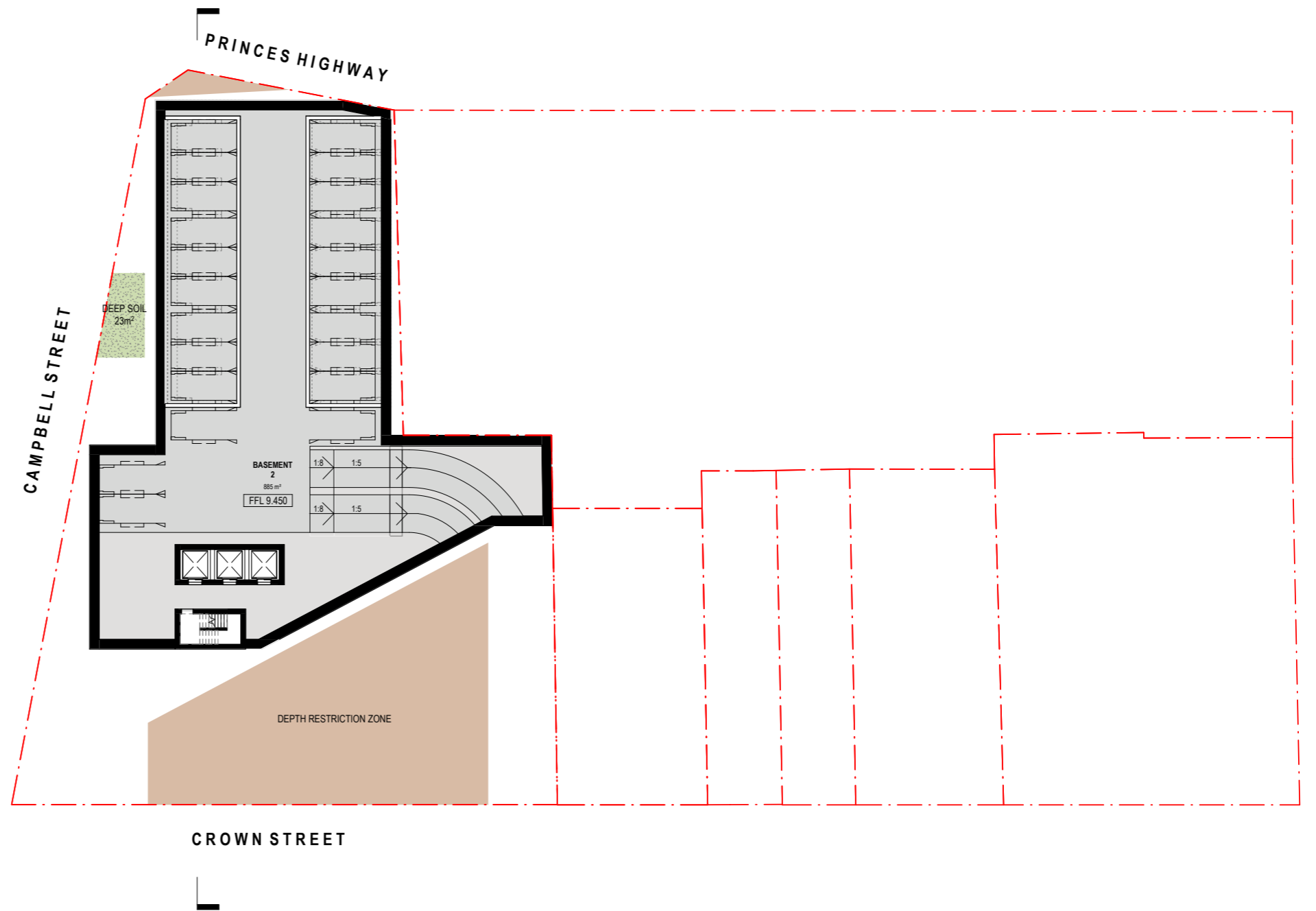

Legend

- Studio
- 1 Bed
- 2 Bed, 2 Bath
- 2 Bed, 1 Bath
- 3 Bed
- Common
- Industrial/Commercial
- Retail/Cafe
- Landscape

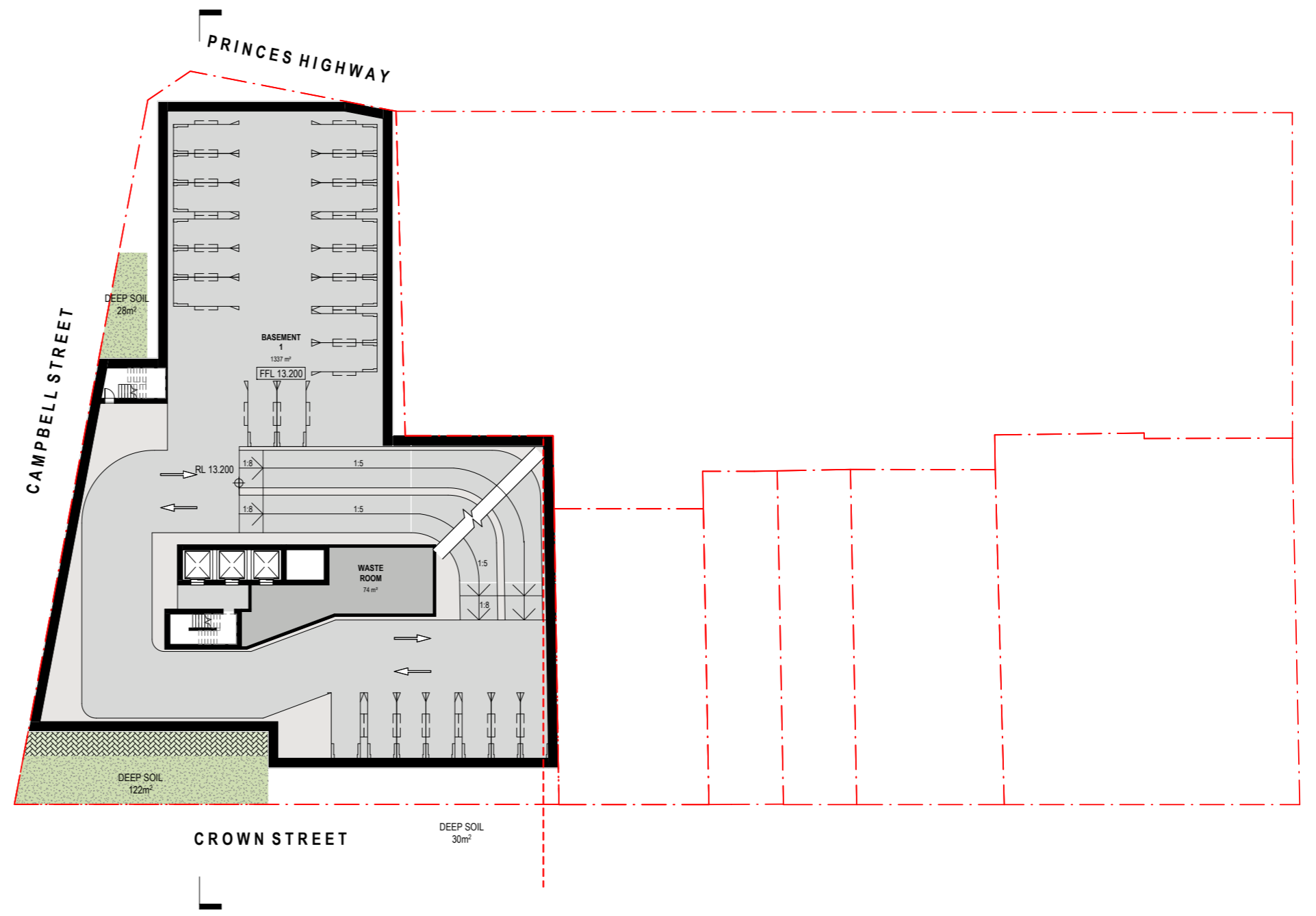

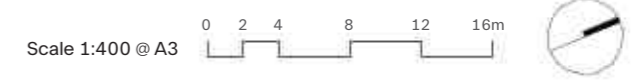

Legend

- Studio
- 1 Bed
- 2 Bed, 2 Bath
- 2 Bed, 1 Bath
- 3 Bed
- Common
- Industrial/Commercial
- Retail/Cafe
- Landscape

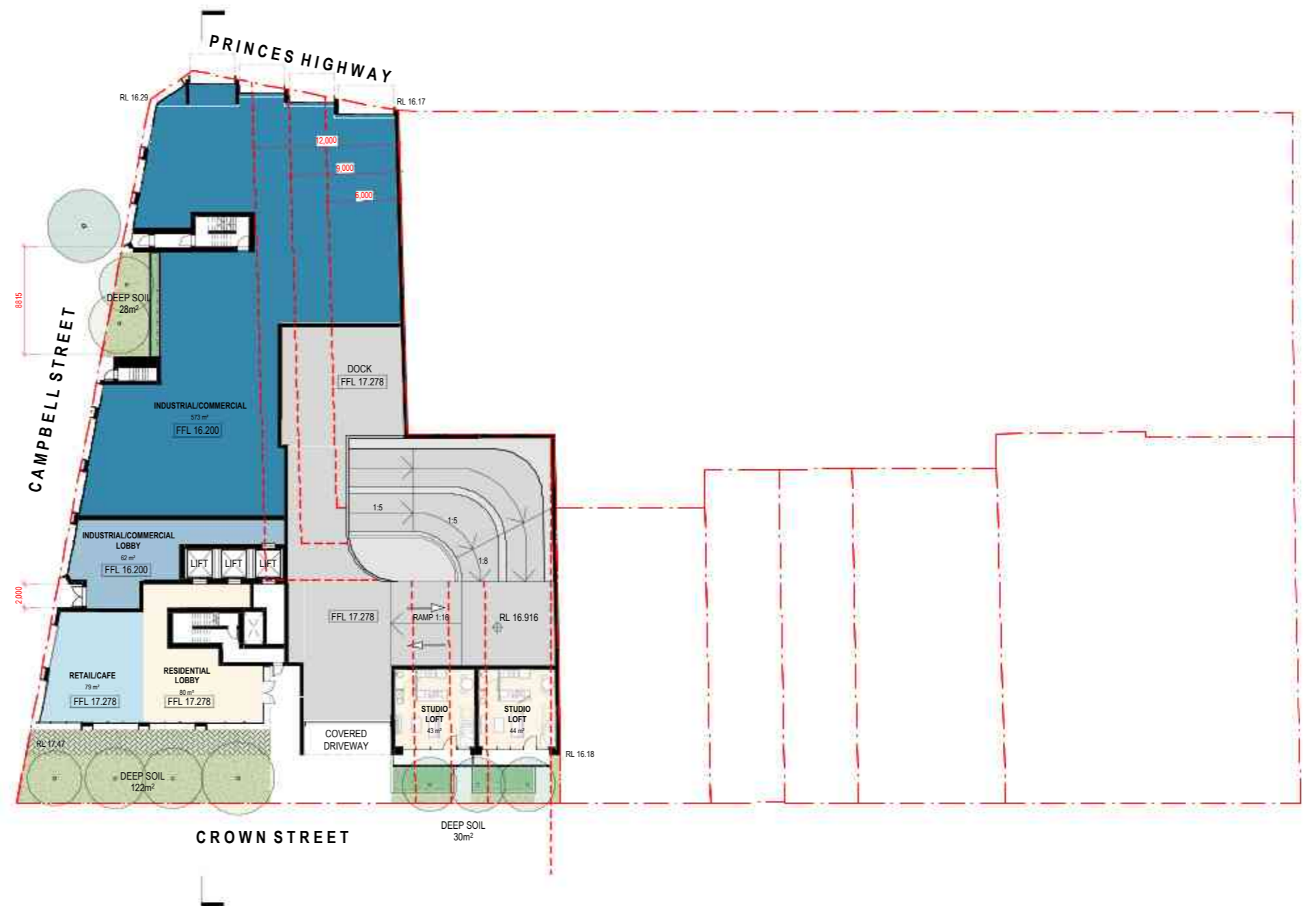

Legend

- Studio
- 1 Bed
- 2 Bed, 2 Bath
- 2 Bed, 1 Bath
- 3 Bed
- Common
- Industrial/Commercial
- Retail/Cafe
- Landscape

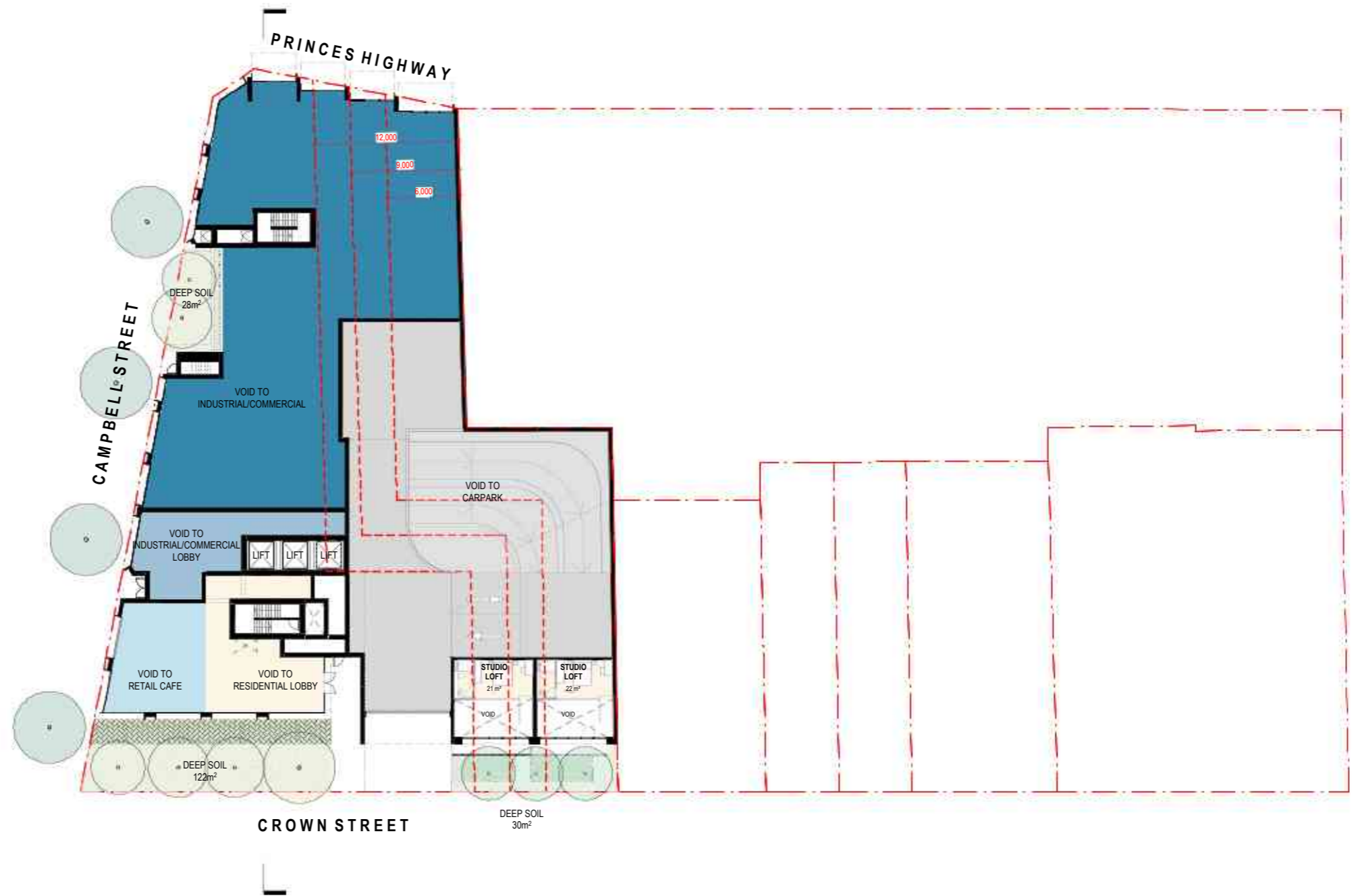

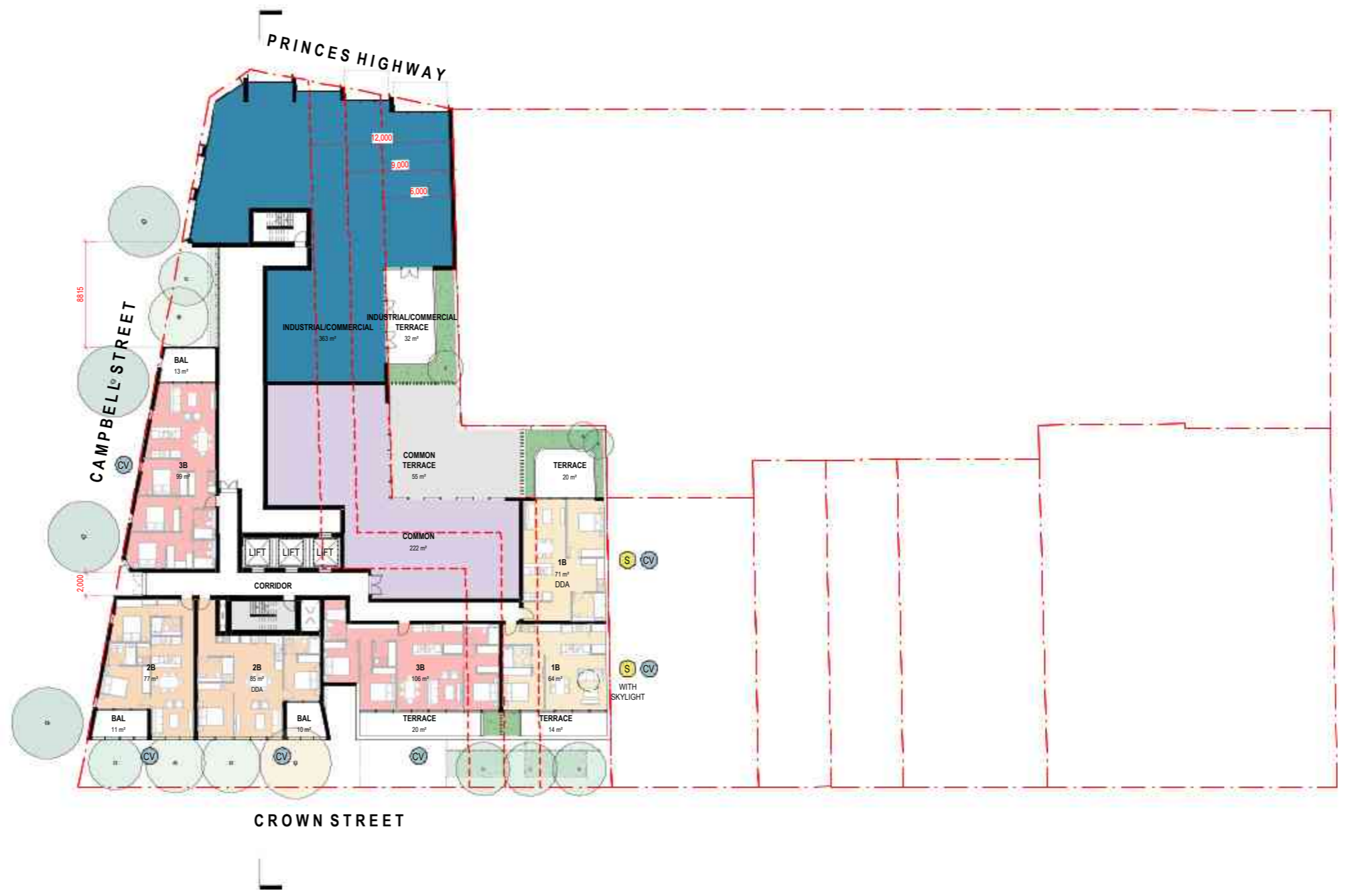
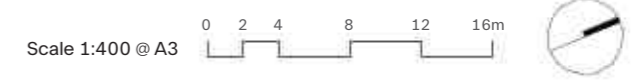

Legend

- Studio
- 1 Bed
- 2 Bed, 2 Bath
- 2 Bed, 1 Bath
- 3 Bed
- Common
- Industrial/Commercial
- Retail/Cafe
- Landscape



Legend

- Studio
- 1 Bed
- 2 Bed, 2 Bath
- 2 Bed, 1 Bath
- 3 Bed
- Common
- Industrial/Commercial
- Retail/Cafe
- Landscape

Attachment 2 : SIDRA Analysis

MOVEMENT SUMMARY

Site: 101 [Existing with Dev PM Peak - Princes Highway/
Barwon Park Road (Site Folder: Existing & Dev)]

Output produced by SIDRA INTERSECTION Version: 9.1.6.228

New Site
Site Category: (None)
Give-Way (Two-Way)

Vehicle Movement Performance															
Mov ID	Turn	Mov Class	Demand Flows		Arrival Flows		Deg. Satn	Aver. Delay	Level of Service	95% Back Of Queue		Prop. Que	Eff. Stop Rate	Aver. No. of Cycles	Aver. Speed
			[Total HV]	%	[Total HV]	%	v/c	sec		[Veh. veh	Dist] m				km/h
South: Princes Highway															
2	T1	All MCs	833	2.1	833	2.1	0.148	0.0	LOS A	0.0	0.0	0.00	0.00	0.00	59.9
Approach			833	2.1	833	2.1	0.148	0.0	NA	0.0	0.0	0.00	0.00	0.00	59.9
SouthEast: Barwon Park Road															
21b	L3	All MCs	62	0.0	62	0.0	0.868	43.6	LOS D	6.0	42.2	1.00	1.64	2.72	19.0
23a	R1	All MCs	42	2.5	42	2.5	0.868	131.8	LOS F	6.0	42.2	1.00	1.64	2.72	16.2
Approach			104	1.0	104	1.0	0.868	79.2	LOS F	6.0	42.2	1.00	1.64	2.72	17.9
North: Princes Highway															
7a	L1	All MCs	37	0.0	37	0.0	0.178	2.4	LOS A	0.0	0.0	0.00	0.22	0.00	55.1
8	T1	All MCs	965	2.0	965	2.0	0.178	0.5	LOS A	0.0	0.0	0.00	0.20	0.00	55.6
Approach			1002	1.9	1002	1.9	0.178	0.6	NA	0.0	0.0	0.00	0.20	0.00	55.6
All Vehicles			1939	2.0	1939	2.0	0.868	4.6	NA	6.0	42.2	0.05	0.19	0.15	43.6

Site Level of Service (LOS) Method: Delay (RTA NSW). Site LOS Method is specified in the Parameter Settings dialog (Options tab).

Vehicle movement LOS values are based on average delay per movement.

Minor Road Approach LOS values are based on average delay for all vehicle movements.

NA (TWSC): Level of Service is not defined for major road approaches or the intersection as a whole for Two-Way Sign Control (HCM LOS rule).

Two-Way Sign Control Capacity Model: SIDRA Standard.

Delay Model: SIDRA Standard (Control Delay: Geometric Delay is included).

Queue Model: SIDRA queue estimation methods are used for Back of Queue and Queue at Start of Gap.

Gap-Acceptance Capacity Formula: SIDRA Standard (Akçelik M3D).

HV (%) values are calculated for All Movement Classes of All Heavy Vehicle Model Designation.

Arrival Flows used in performance calculations are adjusted to include any Initial Queued Demand and Upstream Capacity Constraint effects.

SIDRA INTERSECTION 9.1 | Copyright © 2000-2024 Akcelik and Associates Pty Ltd | sidrasolutions.com

Organisation: PARKING AND TRAFFIC CONSULTANTS | Licence: NETWORK / 1PC | Processed: Wednesday, 20 November 2024 4:40:44 PM

Project: S:\PROJECTS_2021\3285_C&M_85 Crown St, St Peters\4. DA Stage\3. Modelling & Surveys\21-3285 - ptc. SIDRA - [Rev 01].sip9

MOVEMENT SUMMARY

Site: 101 [Existing AM Peak - Princes Highway/Barwon Park Road (Site Folder: Existing)]

Output produced by SIDRA INTERSECTION Version: 9.1.6.228

New Site
 Site Category: (None)
 Give-Way (Two-Way)

Vehicle Movement Performance															
Mov ID	Turn	Mov Class	Demand Flows		Arrival Flows		Deg. Satn	Aver. Delay	Level of Service	95% Back Of Queue		Prop. Que	Eff. Stop Rate	Aver. No. of Cycles	Aver. Speed
			[Total HV]	%	[Total HV]	%	v/c	sec		[Veh. veh	Dist] m				km/h
South: Princes Highway															
2	T1	All MCs	1085	3.8	1085	3.8	0.195	0.0	LOS A	0.0	0.0	0.00	0.00	0.00	59.9
Approach			1085	3.8	1085	3.8	0.195	0.0	NA	0.0	0.0	0.00	0.00	0.00	59.9
SouthEast: Barwon Park Road															
21b	L3	All MCs	47	4.4	47	4.4	0.538	14.6	LOS B	3.1	22.2	1.00	0.94	1.59	27.0
23a	R1	All MCs	41	0.0	41	0.0	0.538	69.7	LOS E	3.1	22.2	1.00	0.94	1.59	23.4
Approach			88	2.4	88	2.4	0.538	40.2	LOS C	3.1	22.2	1.00	0.94	1.59	25.4
North: Princes Highway															
7a	L1	All MCs	37	2.9	37	2.9	0.098	2.4	LOS A	0.0	0.0	0.00	0.25	0.00	54.6
8	T1	All MCs	491	9.7	491	9.7	0.098	0.5	LOS A	0.0	0.0	0.00	0.21	0.00	53.1
Approach			527	9.2	527	9.2	0.098	0.7	NA	0.0	0.0	0.00	0.21	0.00	53.4
All Vehicles			1701	5.4	1701	5.4	0.538	2.3	NA	3.1	22.2	0.05	0.11	0.08	49.0

Site Level of Service (LOS) Method: Delay (RTA NSW). Site LOS Method is specified in the Parameter Settings dialog (Options tab).

Vehicle movement LOS values are based on average delay per movement.

Minor Road Approach LOS values are based on average delay for all vehicle movements.

NA (TWSC): Level of Service is not defined for major road approaches or the intersection as a whole for Two-Way Sign Control (HCM LOS rule).

Two-Way Sign Control Capacity Model: SIDRA Standard.

Delay Model: SIDRA Standard (Control Delay: Geometric Delay is included).

Queue Model: SIDRA queue estimation methods are used for Back of Queue and Queue at Start of Gap.

Gap-Acceptance Capacity Formula: SIDRA Standard (Akçelik M3D).

HV (%) values are calculated for All Movement Classes of All Heavy Vehicle Model Designation.

Arrival Flows used in performance calculations are adjusted to include any Initial Queued Demand and Upstream Capacity Constraint effects.

SIDRA INTERSECTION 9.1 | Copyright © 2000-2024 Akcelik and Associates Pty Ltd | sidrasolutions.com

Organisation: PARKING AND TRAFFIC CONSULTANTS | Licence: NETWORK / 1PC | Processed: Wednesday, 20 November 2024 4:40:43 PM

Project: S:\PROJECTS_2021\3285_C&M_85 Crown St, St Peters\4. DA Stage\3. Modelling & Surveys\21-3285 - ptc. SIDRA - [Rev 01].sip9

MOVEMENT SUMMARY

Site: 101 [Existing PM Peak - Princes Highway/Barwon Park Road (Site Folder: Exisitng)]

Output produced by SIDRA INTERSECTION Version: 9.1.6.228

New Site
 Site Category: (None)
 Give-Way (Two-Way)

Vehicle Movement Performance															
Mov ID	Turn	Mov Class	Demand Flows		Arrival Flows		Deg. Satn	Aver. Delay	Level of Service	95% Back Of Queue		Prop. Que	Eff. Stop Rate	Aver. No. of Cycles	Aver. Speed
			[Total HV]	%	[Total HV]	%	v/c	sec		[Veh. veh	Dist] m				km/h
South: Princes Highway															
2	T1	All MCs	833	2.1	833	2.1	0.148	0.0	LOSA	0.0	0.0	0.00	0.00	0.00	59.9
Approach			833	2.1	833	2.1	0.148	0.0	NA	0.0	0.0	0.00	0.00	0.00	59.9
SouthEast: Barwon Park Road															
21b	L3	All MCs	59	0.0	59	0.0	0.740	25.8	LOS B	4.0	28.2	1.00	1.34	2.08	22.6
23a	R1	All MCs	35	3.0	35	3.0	0.740	112.9	LOS F	4.0	28.2	1.00	1.34	2.08	19.4
Approach			94	1.1	94	1.1	0.740	58.1	LOSE	4.0	28.2	1.00	1.34	2.08	21.4
North: Princes Highway															
7a	L1	All MCs	37	0.0	37	0.0	0.178	2.4	LOSA	0.0	0.0	0.00	0.22	0.00	55.1
8	T1	All MCs	965	2.0	965	2.0	0.178	0.5	LOSA	0.0	0.0	0.00	0.20	0.00	55.6
Approach			1002	1.9	1002	1.9	0.178	0.6	NA	0.0	0.0	0.00	0.20	0.00	55.6
All Vehicles			1928	2.0	1928	2.0	0.740	3.1	NA	4.0	28.2	0.05	0.17	0.10	47.0

Site Level of Service (LOS) Method: Delay (RTA NSW). Site LOS Method is specified in the Parameter Settings dialog (Options tab).

Vehicle movement LOS values are based on average delay per movement.

Minor Road Approach LOS values are based on average delay for all vehicle movements.

NA (TWSC): Level of Service is not defined for major road approaches or the intersection as a whole for Two-Way Sign Control (HCM LOS rule).

Two-Way Sign Control Capacity Model: SIDRA Standard.

Delay Model: SIDRA Standard (Control Delay: Geometric Delay is included).

Queue Model: SIDRA queue estimation methods are used for Back of Queue and Queue at Start of Gap.

Gap-Acceptance Capacity Formula: SIDRA Standard (Akçelik M3D).

HV (%) values are calculated for All Movement Classes of All Heavy Vehicle Model Designation.

Arrival Flows used in performance calculations are adjusted to include any Initial Queued Demand and Upstream Capacity Constraint effects.

SIDRA INTERSECTION 9.1 | Copyright © 2000-2024 Akcelik and Associates Pty Ltd | sidrasolutions.com

Organisation: PARKING AND TRAFFIC CONSULTANTS | Licence: NETWORK / 1PC | Processed: Wednesday, 20 November 2024 4:40:43 PM

Project: S:\PROJECTS_2021\3285_C&M_85 Crown St, St Peters\4. DA Stage\3. Modelling & Surveys\21-3285 - ptc. SIDRA - [Rev 01].sip9

MOVEMENT SUMMARY

Site: 101 [Existing with Dev AM Peak - Princes Highway/
Barwon Park Road (Site Folder: Existing & Dev)]

Output produced by SIDRA INTERSECTION Version: 9.1.6.228

New Site
Site Category: (None)
Give-Way (Two-Way)

Vehicle Movement Performance															
Mov ID	Turn	Mov Class	Demand Flows		Arrival Flows		Deg. Satn	Aver. Delay	Level of Service	95% Back Of Queue		Prop. Que	Eff. Stop Rate	Aver. No. of Cycles	Aver. Speed
			[Total HV]	%	[Total HV]	%	v/c	sec		[Veh. veh	Dist] m				km/h
South: Princes Highway															
2	T1	All MCs	1085	3.8	1085	3.8	0.195	0.0	LOS A	0.0	0.0	0.00	0.00	0.00	59.9
Approach			1085	3.8	1085	3.8	0.195	0.0	NA	0.0	0.0	0.00	0.00	0.00	59.9
SouthEast: Barwon Park Road															
21b	L3	All MCs	60	3.5	60	3.5	0.906	52.7	LOS D	10.0	71.0	1.00	1.72	3.13	17.7
23a	R1	All MCs	71	0.0	71	0.0	0.906	120.3	LOS F	10.0	71.0	1.00	1.72	3.13	15.1
Approach			131	1.6	131	1.6	0.906	89.2	LOS F	10.0	71.0	1.00	1.72	3.13	16.3
North: Princes Highway															
7a	L1	All MCs	37	2.9	37	2.9	0.098	2.4	LOS A	0.0	0.0	0.00	0.25	0.00	54.6
8	T1	All MCs	491	9.7	491	9.7	0.098	0.5	LOS A	0.0	0.0	0.00	0.21	0.00	53.1
Approach			527	9.2	527	9.2	0.098	0.7	NA	0.0	0.0	0.00	0.21	0.00	53.4
All Vehicles			1743	5.3	1743	5.3	0.906	6.9	NA	10.0	71.0	0.07	0.19	0.23	39.0

Site Level of Service (LOS) Method: Delay (RTA NSW). Site LOS Method is specified in the Parameter Settings dialog (Options tab).

Vehicle movement LOS values are based on average delay per movement.

Minor Road Approach LOS values are based on average delay for all vehicle movements.

NA (TWSC): Level of Service is not defined for major road approaches or the intersection as a whole for Two-Way Sign Control (HCM LOS rule).

Two-Way Sign Control Capacity Model: SIDRA Standard.

Delay Model: SIDRA Standard (Control Delay: Geometric Delay is included).

Queue Model: SIDRA queue estimation methods are used for Back of Queue and Queue at Start of Gap.

Gap-Acceptance Capacity Formula: SIDRA Standard (Akçelik M3D).

HV (%) values are calculated for All Movement Classes of All Heavy Vehicle Model Designation.

Arrival Flows used in performance calculations are adjusted to include any Initial Queued Demand and Upstream Capacity Constraint effects.

SIDRA INTERSECTION 9.1 | Copyright © 2000-2024 Akcelik and Associates Pty Ltd | sidrasolutions.com

Organisation: PARKING AND TRAFFIC CONSULTANTS | Licence: NETWORK / 1PC | Processed: Wednesday, 20 November 2024 4:40:43 PM

Project: S:\PROJECTS_2021\3285_C&M_85 Crown St, St Peters\4. DA Stage\3. Modelling & Surveys\21-3285 - ptc. SIDRA - [Rev 01].sip9

Attachment 3 : Swept Paths & Design Commentary

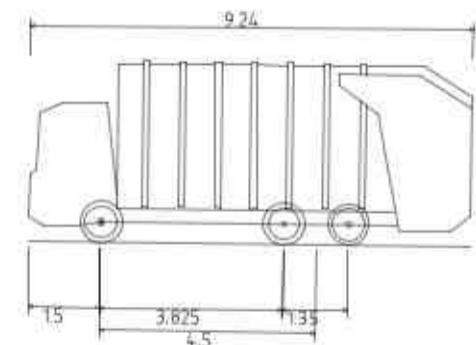
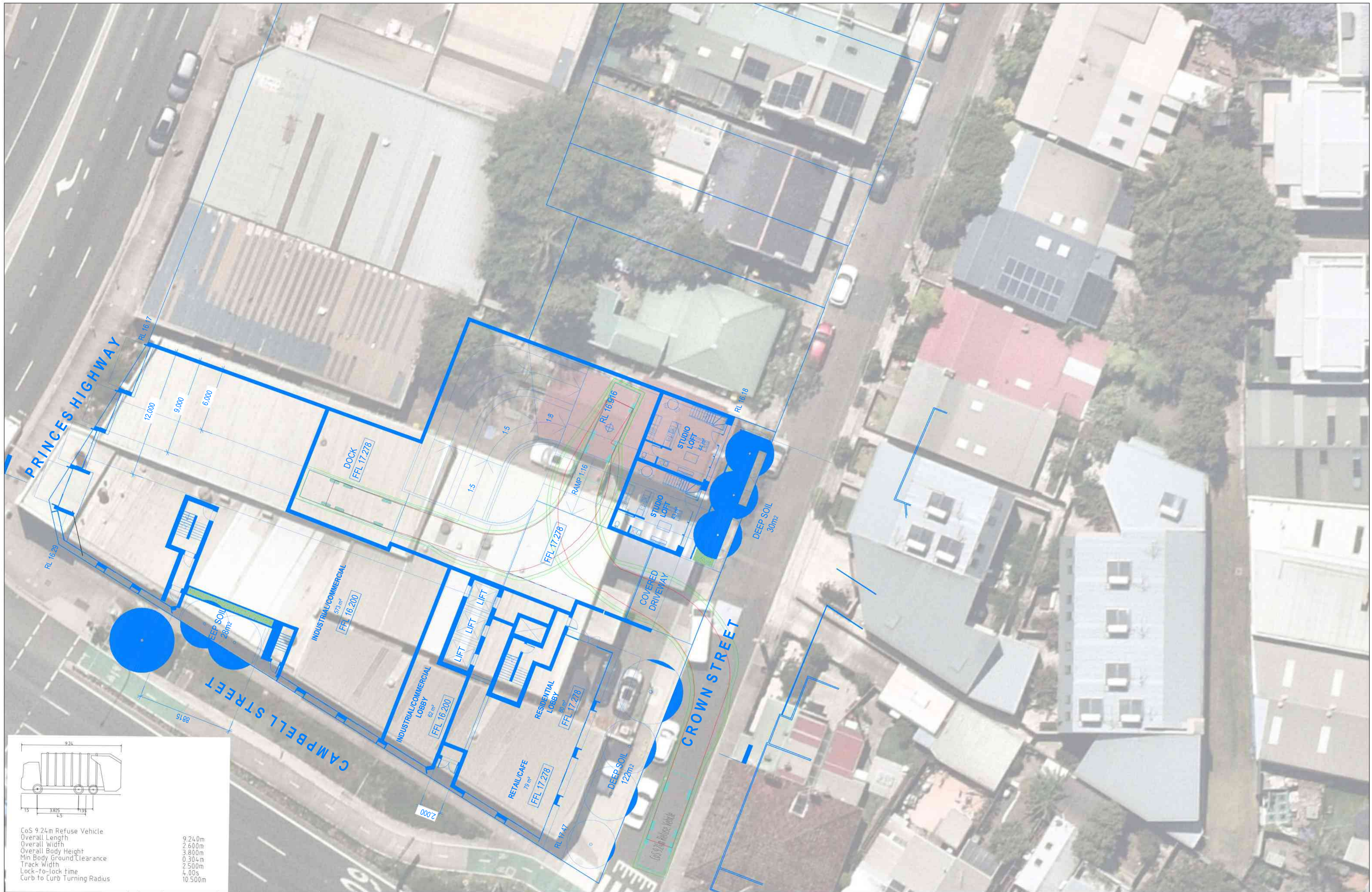

CoS 9.24m Refuse Vehicle
 Overall Length 9.240m
 Overall Width 2.600m
 Overall Body Height 3.800m
 Min Body Ground Clearance 0.304m
 Track Width 2.500m
 Lock-to-lock time 4.00s
 Curb to Curb Turning Radius 10.500m

ptc.

Suite 502, 1 James
 Place
 North Sydney NSW
 2060
 T +61 2 8920 0800
 ptcconsultants.co

REV	DATE	DESCRIPTION	DRAWN	REVIEWED
X	X	X	X	X
X	X	X	X	X
X	X	X	X	X
P4	27/11/24	FOR INFORMATION	MA	SW
P3	22/11/24	FOR INFORMATION	MA	SW
P2	14/11/24	FOR INFORMATION	MA	SW
P1	13/11/24	FOR INFORMATION	MA	SW

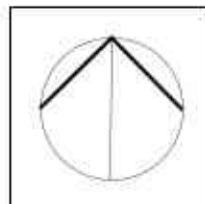

DRAWING KEY

PROJECT
 75-85 CROWN STREET AND
 116 PRINCESS HIGHWAY, ST
 PETERS

DRAWING TITLE
 WASTE COLLECTION VEHICLE SWEEP
 PATHS

CLIENT PETER ANTONIOU
 DRAWING # 01C-0001
 PROJECT # 021-3285
 SCALE 1 : 100 @ A1

PRELIMINARY

REV P4

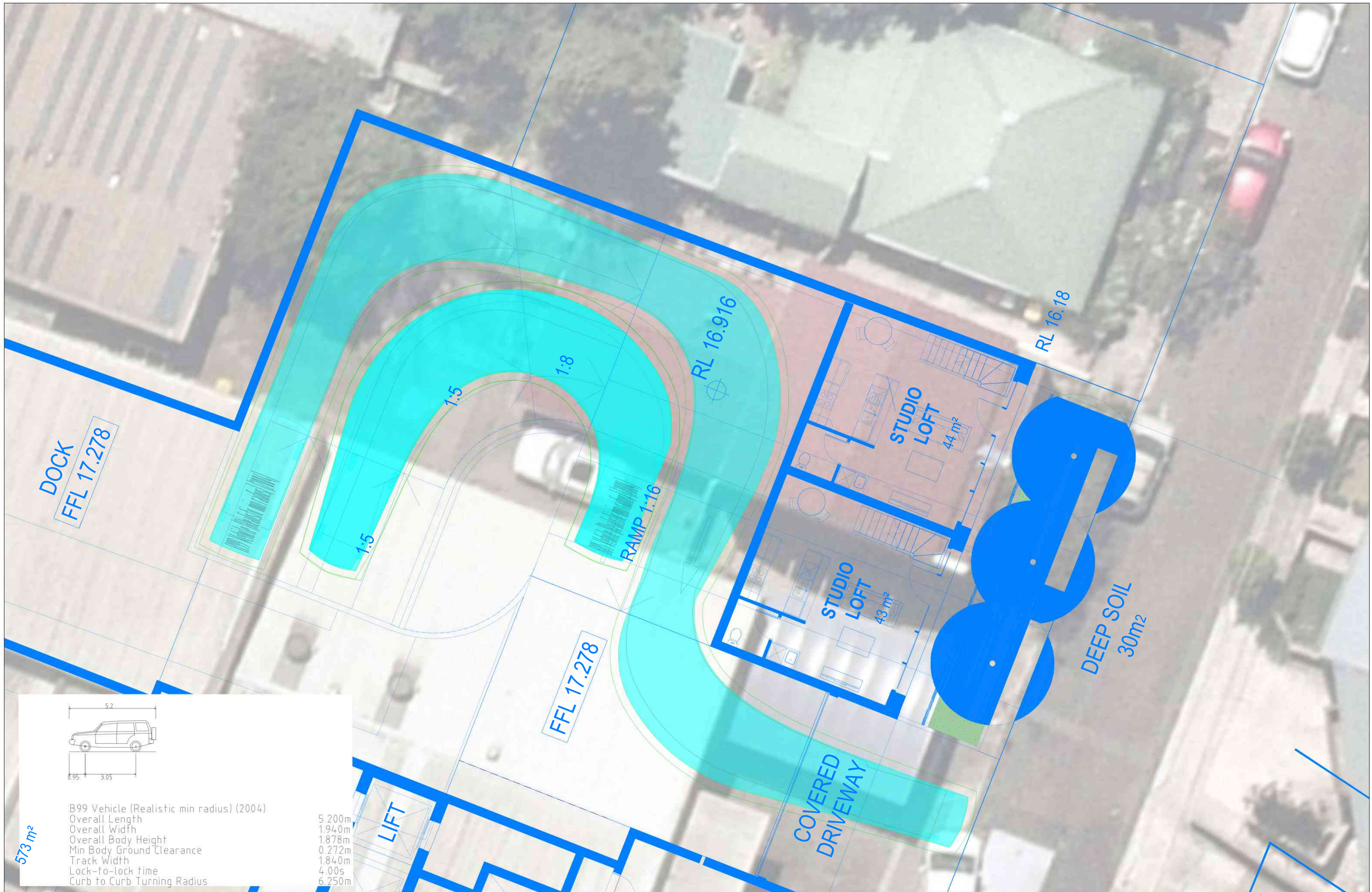

DOCK
FFL 17.278

RL 16.916

RL 16.18

RAMP 1:16

STUDIO LOFT
44 m²

STUDIO LOFT
43 m²

DEEP SOIL
30m²

COVERED DRIVEWAY

LIFT

FFL 17.278

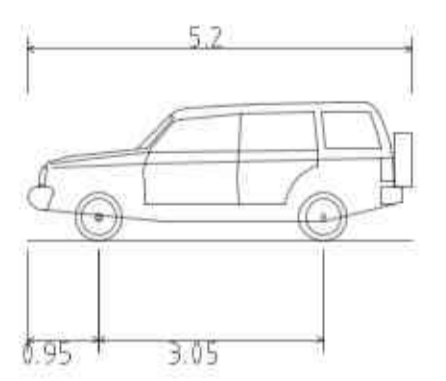

B99 Vehicle (Realistic min radius) (2004)
 Overall Length 5.200m
 Overall Width 1.940m
 Overall Body Height 1.878m
 Min Body Ground Clearance 0.272m
 Track Width 1.840m
 Lock-to-lock time 4.00s
 Curb to Curb Turning Radius 6.250m

573 m²

ptc.
 Suite 502, 1 James Place
 North Sydney NSW, 2060
 T +61 2 8920 0800
 ptcconsultants.co

REV	DATE	DESCRIPTION	DRAWN	REVIEWED
P4	27/11/24	FOR INFORMATION	MA	SW
P3	22/11/24	FOR INFORMATION	MA	SW
P2	14/11/24	FOR INFORMATION	MA	SW
P1	13/11/24	FOR INFORMATION	MA	SW

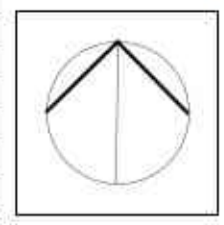

DRAWING KEY

PROJECT
 75-85 CROWN STREET AND
 116 PRINCESS HIGHWAY, ST
 PETERS

DRAWING TITLE
 RAMP - VEHICLE SWEPT PATHS

CLIENT PETER ANTONIOU
 DRAWING # 01C-0002
 PROJECT # 021-3285
 SCALE 1 : 100 @ A1

PRELIMINARY
 REV P4

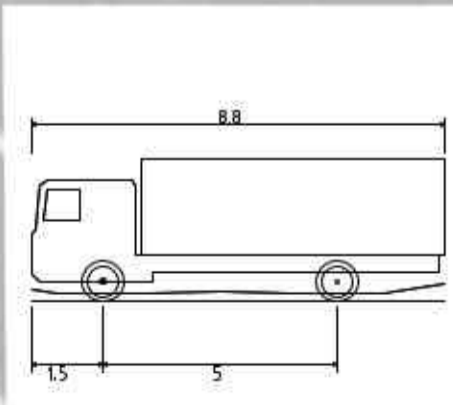
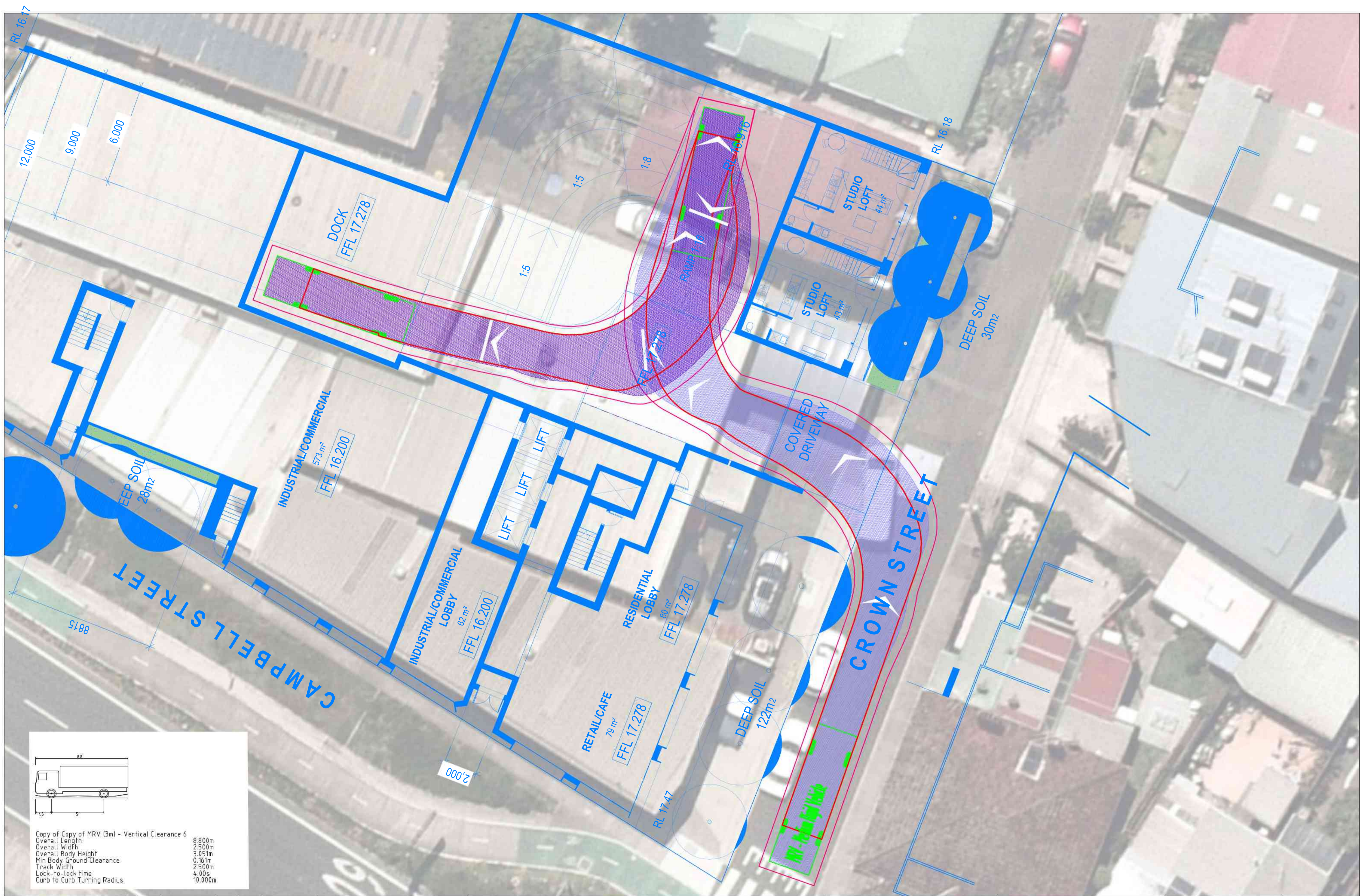

Copy of Copy of MRV (3m) - Vertical Clearance 6
 Overall Length 8.800m
 Overall Width 2.500m
 Overall Body Height 3.051m
 Min Body Ground Clearance 0.161m
 Track Width 2.500m
 Lock-to-lock time 4.00s
 Curb to Curb Turning Radius 10.000m

ptc.

Suite 502, 1 James
 Place
 North Sydney NSW,
 2060
 I +61 2 8920 0800
 ptcconsultants.co

REV	DATE	DESCRIPTION	DRAWN	REVIEWED
X	X	X	X	X
X	X	X	X	X
X	X	X	X	X
P4	27/11/24	FOR INFORMATION	MA	SW
P3	22/11/24	FOR INFORMATION	MA	SW
P2	14/11/24	FOR INFORMATION	MA	SW
P1	13/11/24	FOR INFORMATION	MA	SW

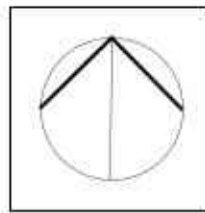

DRAWING KEY

PROJECT
 75-85 CROWN STREET AND
 116 PRINCESS HIGHWAY, ST
 PETERS

DRAWING TITLE
 SERVICE VEHICLE SWEEP PATHS

CLIENT PETER ANTONIOU
 DRAWING # 01C-0005
 PROJECT # 021-3285
 SCALE 1 : 100 @ A1

PRELIMINARY

REV P4

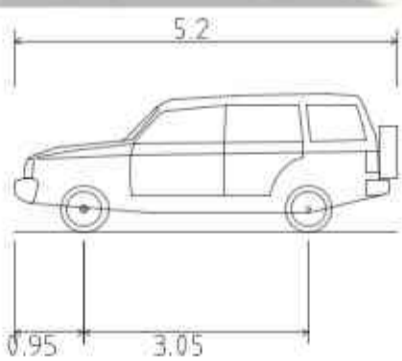
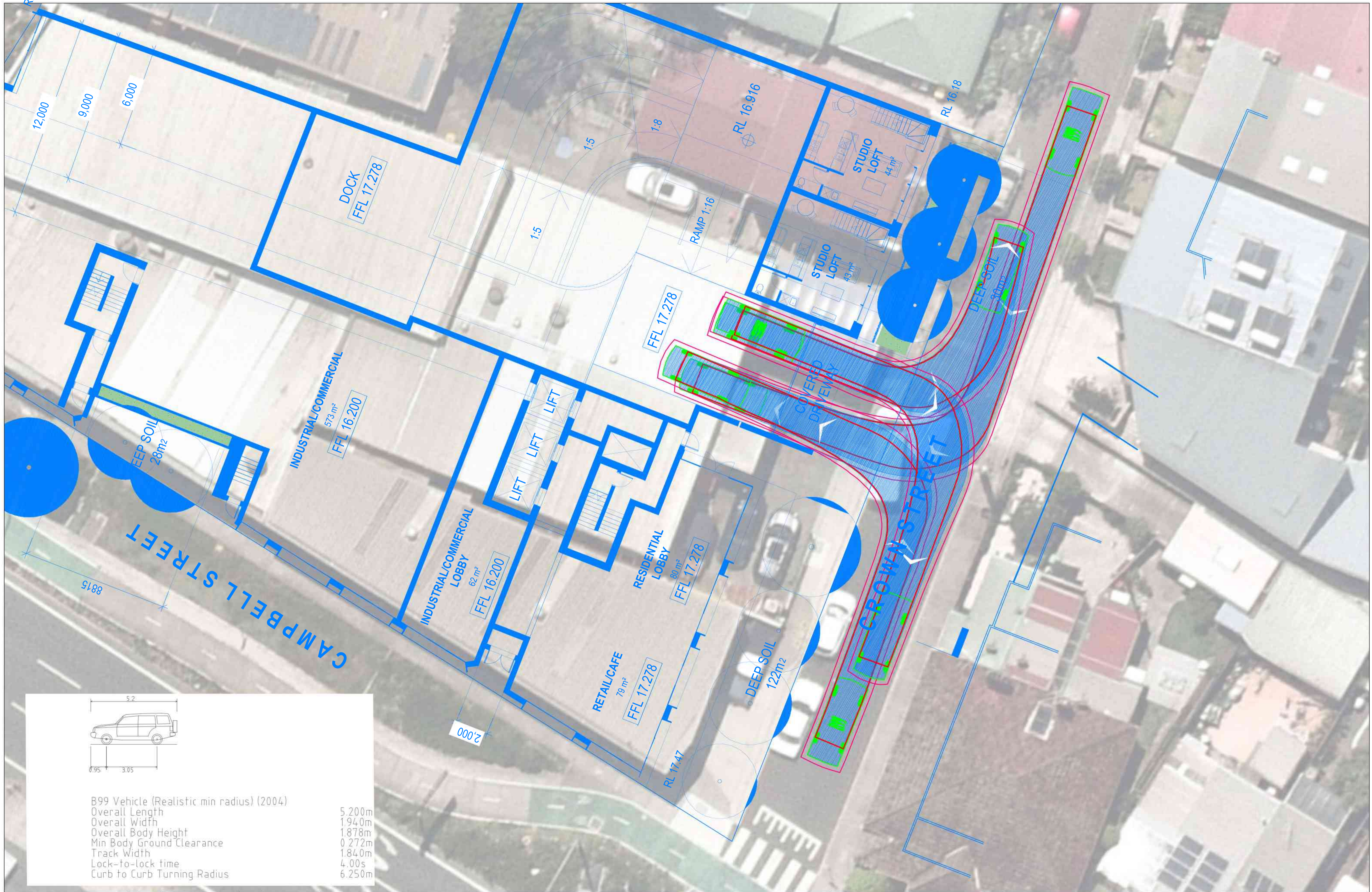

B99 Vehicle (Realistic min radius) (2004)
 Overall Length 5.200m
 Overall Width 1.940m
 Overall Body Height 1.878m
 Min Body Ground Clearance 0.272m
 Track Width 1.840m
 Lock-to-lock time 4.00s
 Curb to Curb Turning Radius 6.250m



Suite 502, 1 James
 Place
 North Sydney NSW
 2060
 T +61 2 8920 0800
 ptcconsultants.co

REV	DATE	DESCRIPTION	DRAWN	REVIEWED
P4	27/11/24	FOR INFORMATION	MA	SW
P3	22/11/24	FOR INFORMATION	MA	SW
P2	14/11/24	FOR INFORMATION	MA	SW
P1	13/11/24	FOR INFORMATION	MA	SW

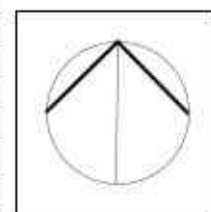

DRAWING KEY

PROJECT
 75-85 CROWN STREET AND
 116 PRINCESS HIGHWAY, ST
 PETERS

DRAWING TITLE
 B99 SWEEP PATHS

CLIENT PETER ANTONIOU
 DRAWING # 01C-0004
 PROJECT # 021-3285
 SCALE 1 : 100 @ A1

PRELIMINARY
 REV P4

PRINCES HIGHWAY

CAMPBELL STREET

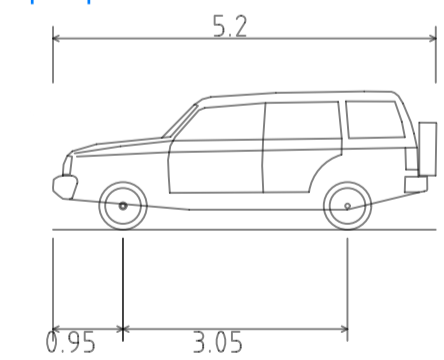
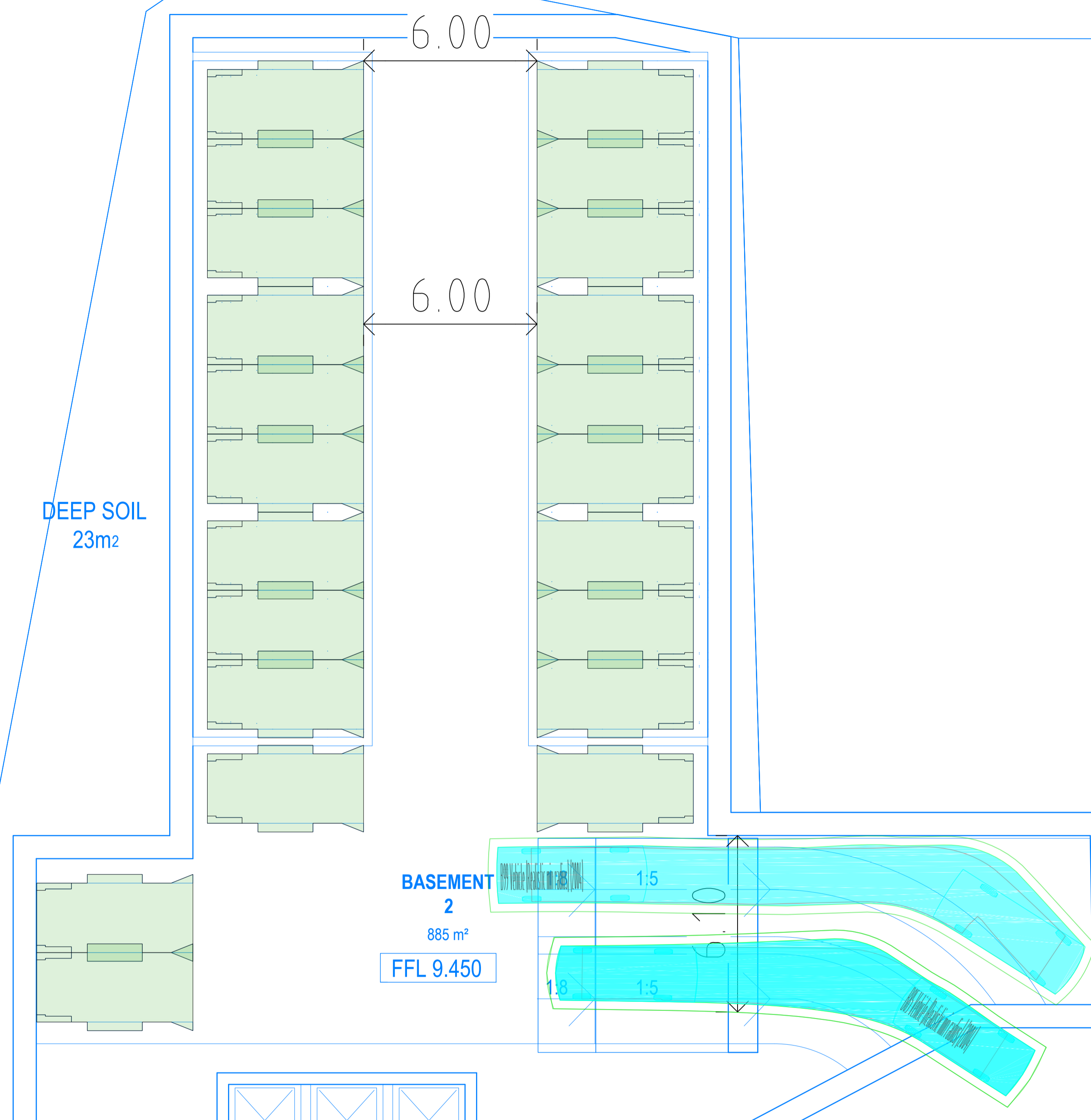

B99 Vehicle (Realistic min radius) (2004)

Overall Length	5.200m
Overall Width	1.940m
Overall Body Height	1.878m
Min Body Ground Clearance	0.272m
Track Width	1.840m
Lock-to-lock time	4.00s
Curb to Curb Turning Radius	6.250m

PRINCES HIGHWAY

CAMPBELL STREET

CROWN STREET

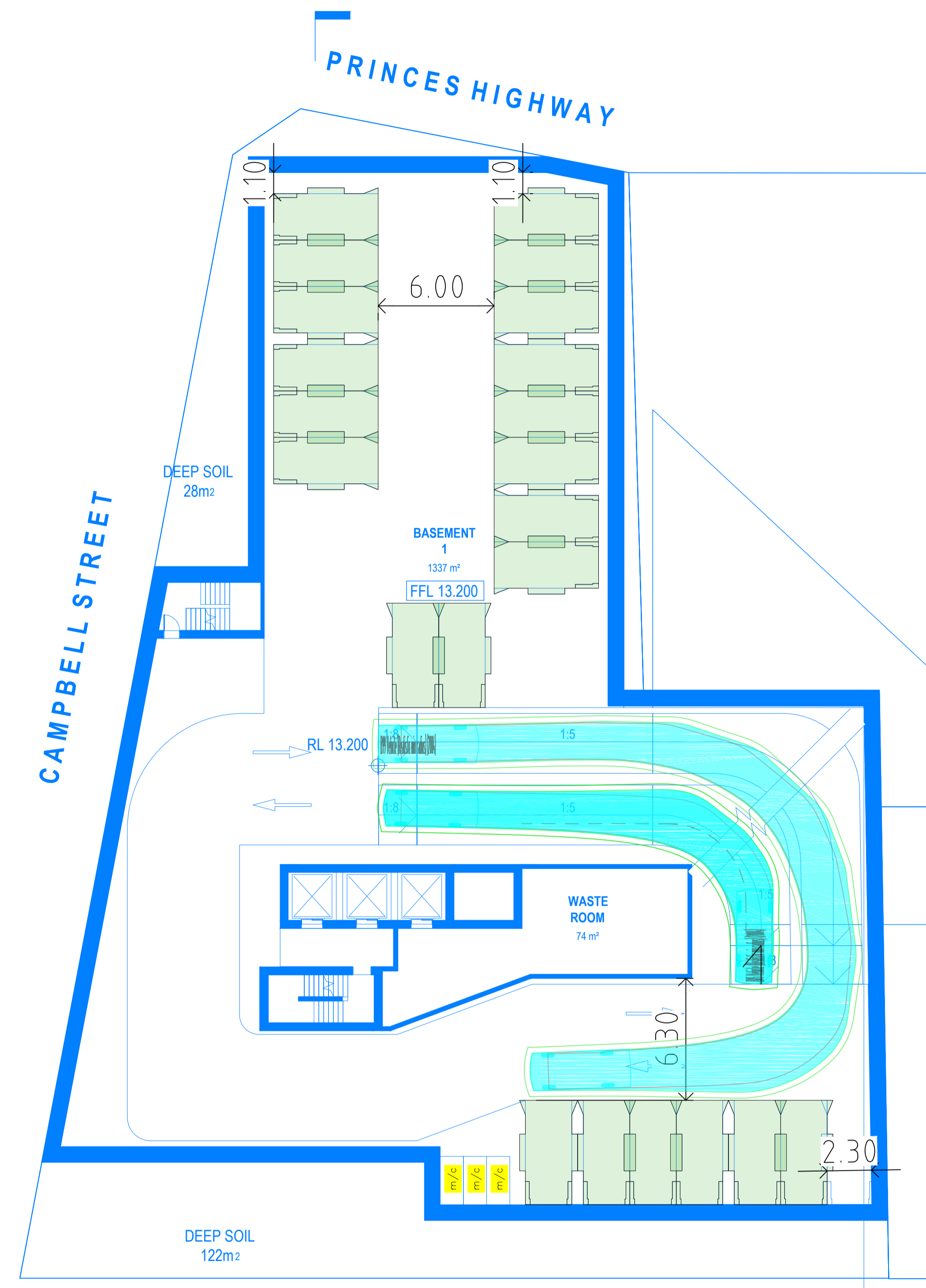

ptc.	Suite 502, 1 James Place North Sydney NSW 2060 t +61 2 8920 0800 ptcconsultants.co	<table border="1"> <tr> <td>X</td><td>X</td><td>X</td><td>X</td><td>X</td><td>X</td> </tr> <tr> <td>X</td><td>X</td><td>X</td><td>X</td><td>X</td><td>X</td> </tr> <tr> <td>X</td><td>X</td><td>X</td><td>X</td><td>X</td><td>X</td> </tr> <tr> <td>P4</td><td>27/11/24</td><td>FOR INFORMATION</td><td>MA</td><td>SW</td><td></td> </tr> <tr> <td>P3</td><td>22/11/24</td><td>FOR INFORMATION</td><td>MA</td><td>SW</td><td></td> </tr> <tr> <td>P2</td><td>14/11/24</td><td>FOR INFORMATION</td><td>MA</td><td>SW</td><td></td> </tr> <tr> <td>P1</td><td>13/11/24</td><td>FOR INFORMATION</td><td>MA</td><td>SW</td><td></td> </tr> <tr> <td>REV</td><td>DATE</td><td>DESCRIPTION</td><td>DRAWN</td><td>REVIEWED</td><td></td> </tr> </table>	X	X	X	X	X	X	X	X	X	X	X	X	X	X	X	X	X	X	P4	27/11/24	FOR INFORMATION	MA	SW		P3	22/11/24	FOR INFORMATION	MA	SW		P2	14/11/24	FOR INFORMATION	MA	SW		P1	13/11/24	FOR INFORMATION	MA	SW		REV	DATE	DESCRIPTION	DRAWN	REVIEWED	
	X	X	X	X	X	X																																												
X	X	X	X	X	X																																													
X	X	X	X	X	X																																													
P4	27/11/24	FOR INFORMATION	MA	SW																																														
P3	22/11/24	FOR INFORMATION	MA	SW																																														
P2	14/11/24	FOR INFORMATION	MA	SW																																														
P1	13/11/24	FOR INFORMATION	MA	SW																																														
REV	DATE	DESCRIPTION	DRAWN	REVIEWED																																														
		DRAWING KEY																																																

PROJECT	75-85 CROWN STREET AND 116 PRINCESS HIGHWAY, ST PETERS
DRAWING TITLE	B1 & B2 ASSESSMENT
CLIENT	PETER ANTONIOU
DRAWING #	01C-0005
PROJECT #	021-3285
SCALE	1 : 100 @ A1

PRELIMINARY	REV P4
-------------	--------