

PLAN

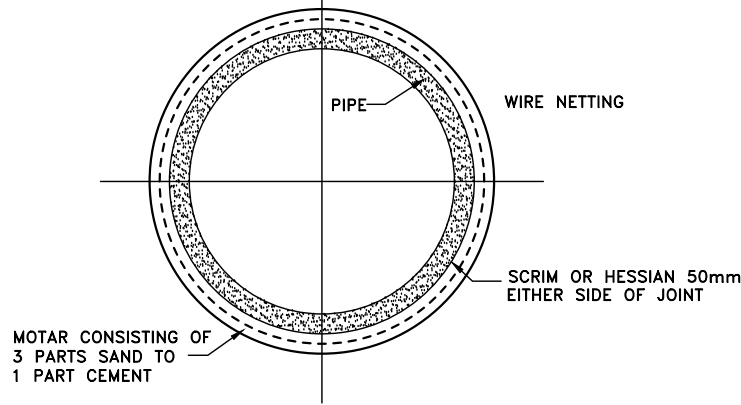

SECTION

**NOTE:**  
 BANDAGED JOINTS SHALL BE USED FOR JUNCTIONS BETWEEN CONCRETE, VITRIFIED CLAY AND/OR ASBESTOS CEMENT PIPELINES. THE JOINTS SHALL BE CONSTRUCTED BY CAREFULLY CUTTING THE PIPES SO THAT A NEAT FIT IS OBTAINED THEN JOINED IN-SITU. THE INSIDE SHALL BE NEATLY AND SMOOTHLY FINISHED IN CEMENT MORTAR TO MAINTAIN THE SLOPE OF THE ORIGINAL PIPES.

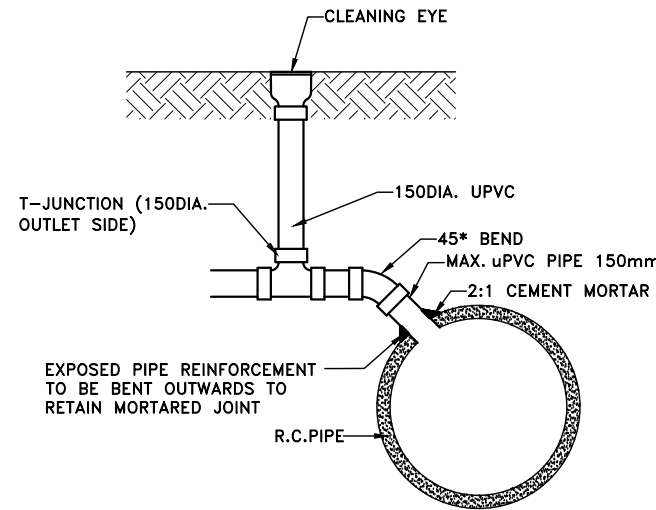

CONNECTION OF DRAINAGE LINE

**NOTE:**  
 THE R.C. STORMWATER PIPE SHALL BE PIERCED BY A NEAT OPENING TO ALLOW THE CONNECTION OF A PVC PIPE WHICH SHALL NOT PROTRUDE BEYOND THE INNER SURFACE OF THE R.C. STORMWATER PIPE. THE INTERNAL JUNCTION SHALL BE SMOOTHLY FINISHED WITH 2:1 CEMENT MORTAR SO AS TO PRESENT NO OBSTRUCTION WITHIN THE INTERNAL CHANNEL OF THE R.C. STORMWATER PIPE - THIS SHALL BE DONE BEFORE THE 45\* BEND IS INSTALLED.

**DRAINAGE NOTES 5:**

1. **EXCAVATION**
  - A) AT ALL JOINS TO EXISTING CONCRETE/ASPHALT - THE JOIN SHALL BE SAW CUT BEFORE EXCAVATION.
  - B) ALL EXCAVATED MATERIAL SHALL BE REMOVED FROM THE SITE AND DISPOSED OF AT A LICENSED WASTE DISPOSAL FACILITY.
2. **UTILITIES, SERVICES & SURVEY MARKS**
  - A) ALL UNDERGROUND UTILITY SERVICES SHALL BE CHECKED FOR LEVEL AND LOCATION PRIOR TO COMMENCEMENT OF WORKS, BY THE CONTRACTOR.
  - B) ALL SERVICE COVERS AFFECTED BY THE WORKS SHALL BE ADJUSTED AS REQUIRED AND TO SUIT THE LEVELS OF THE NEW WORK. NO SERVICE FITTINGS SHALL BE COVERED.
  - C) PROPERTY STORMWATER PIPES: WHERE AFFECTED, SHALL BE REPLACED WITH 90MM UPVC OR TO SUIT EXISTING AND INVERT SHALL MATCH THE GUTTER LEVEL.
  - D) STATE SURVEY MARKS (SSMS) - SHALL NOT BE DISTURBED UNLESS APPROVED BY THE COUNCIL ENGINEER.
  - E) AT ALL LIGHT/POWER POLES, THE CONCRETE SHALL BE ENDED 150MM CLEAR OF THE POLE AND THE GAP FILLED WITH 30MM OF 10MM COLDMIX/ASPHALTIC CONCRETE.
3. **NATURE STRIP RESTORATION**
  - A) MATCH EXISTING TURF.
  - B) IF NEW TURF IS SPECIFIED - USE SOFT LEAF BUFFALO 'SHADEMASTER', LAID ON 100MM THICK PREPARED TOPSOIL, AS SPECIFIED BY THE COUNCIL ENGINEER.
4. **EXISTING SIGNAGE**
  - A) SUCH SIGNAGE SHALL BE REINSTATED UNLESS THE COUNCIL ENGINEER ADVISES OTHERWISE.
  - B) SIGNS REPLACED OR NEW, WITHIN THE NEW CONCRETE SHALL BE INSTALLED WITH A V-LOK.
  - C) HERITAGE STREET NAME SIGNS EMBEDDED IN FOOTPATH PAVING AND KERBS - CAUTION SHALL BE EXERCISED TO NOT DAMAGE THESE SIGNS AND THE CONTRACTOR SHALL LIAISE WITH THE COUNCIL ENGINEER TO DETERMINE WHAT ACTION TO IMPLEMENT WHERE DISTURBANCE OF THE SIGN IS ESSENTIAL.
5. **RESIDENT NOTIFICATION**
  - A) ALL RESIDENTS AFFECTED BY THE WORKS SHALL BE NOTIFIED AT LEAST 2 WORKING DAYS BEFORE THE RELEVANT WORK COMMENCES AND ANY REASONABLE REQUESTS ACCOMMODATED.
6. **SAFETY/SIGNAGE/ACCESS**
  - A) DURING CONSTRUCTION, ADEQUATE WARNING SIGNS AND BARRICADING SHALL BE PROVIDED TO ENSURE THAT THE WORK SITE MEETS THE REQUIREMENTS OF AS 1742.2 & 1743.3, AND TO PROVIDE ADEQUATE PROTECTION TO PEDESTRIANS & MOTORISTS.
  - B) ADEQUATE AND SAFE ACCESS FOR PEDESTRIANS SHALL BE PROVIDED AT ALL TIMES.
  - C) AT DRIVEWAYS - PREVENTION OF ACCESS SHALL BE KEPT TO AN ABSOLUTE MINIMUM AND ARRANGEMENTS SHALL BE MADE WITH THE RESIDENT/BUSINESS, BY THE CONTRACTOR, FOR A SUITABLE DAY/TIME FOR THIS WORK. USE OF HIGHER STRENGTH CONCRETE, WITH SHORTER CURING TIME MAY BE NECESSARY.
7. **DIMENSIONS**
  - A) ALL DIMENSIONS ARE IN MILLIMETERS UNLESS SHOWN OTHERWISE.
8. **GENERAL**
  - A) ALL WORKS SHALL BE CARRIED OUT TO COUNCIL'S SPECIFICATION, TO BEST PRACTICE STANDARDS, AND TO THE SATISFACTION OF COUNCIL'S SUPERVISING ENGINEER.
  - B) THE WORK SITE SHALL BE KEPT IN A CLEAN, TIDY, AND SAFE CONDITION AT ALL TIMES AND TO THE SATISFACTION OF COUNCIL'S ENGINEER.
9. **DOCUMENT PRIORITY**
  - A) THIS PLAN SUPERSEDES ANY STATEMENTS ON OTHER DOCUMENTS, EG SPECIFICATIONS, OTHER PLANS, ETC, UNLESS ADVISED BY THE COUNCIL ENGINEER.
10. **INSPECTIONS**

INSPECTIONS BY THE COUNCIL SUPERVISING ENGINEER SHALL BE REQUIRED AT THE FOLLOWING STAGES AND AS OTHERWISE DIRECTED BY THE COUNCIL ENGINEER:-

  - A) EXCAVATION COMPLETED.
  - B) PIPE CONNECTION AND MAIN DRAINAGE LINE COMPLETED BUT 45\* BEND NOT INSTALLED.
  - C) ALL PIPES LAID BUT NOT BACKFILLED.
  - D) TOTALLY COMPLETED.
  - E) IN SOME CASES, COUNCIL MAY REQUIRE A CCTV SURVEY ON COMPLETION OF THE CONNECTION.

(ORIGINAL = A3 SHEET)

CHECKED & APPROVED	SURVEYED & DRAFTED	QUANTITIES	SERVICES AFFECTED	S.R.A. / SURV. GEN.	SERVICES	DATUM	INNER WEST COUNCIL	FILE NO.	SHEET NO.
	DESIGNED PG/DJT MAY 2019			R.T.A.	TELECOM/OPTUS -T-T-T-T-	A. H. D.	STANDARD DRAINAGE DRAWING - D9		
APPROVED FOR CONSTRUCTION	DRAWN PG/DJT MAY 2019			A.G.L. / SHELL PIPELINES	GAS -G-G-G-G-	NTS		BANDAGE JOINT & MINOR PIPE CONNECTION	PLAN NO.
				SYDNEY WATER	SEWER -S-S-S-S-		TO STORMWATER PIPE - DETAIL	VERSION	V1
				TELSTRA / OPTUS	WATER -W-W-W-W-				
				SYDNEY ELECTRICITY	RAILWAY -R-R-R-R-				
				NOTICE OF ENTRY	ELEC. CABLES -E-E-E-E-				
				KERB & GUTTER	OIL PIPELINES -P-P-P-P-				
				NOTICES	STORM WATER -SW-SW-SW-				
				DATE					