

3 June 2016

Dear Resident

## Geotechnical investigations – Leichhardt

Work is underway on WestConnex which involves widening and extending the M4 and M5 and joining them to create a free-flowing motorway network.

Recently, planning commenced for the proposed M4-M5 Link – the final stage of the WestConnex project linking the M4 at Haberfield to the M5 at St Peters via underground tunnels. For more information, visit [westconnex.com.au/M4-M5Link](http://westconnex.com.au/M4-M5Link).

Further to our previous notification, geotechnical investigations will be undertaken in various locations along Darley Road, near Charles Street and Elswick Street, Leichhardt. This work will take up to three weeks from **Thursday, 9 June 2016**.

Generally, work will take place **between 7.00 am and 6.00 pm from Monday to Friday and 8.00 am and 1.00 pm on Saturday**. There will be no work on Sunday or public holidays. A diagram showing how geotechnical samples are taken is shown overleaf.

The work at each location is expected to take about a week to complete, weather permitting, and will involve:

- identifying underground services and utilities and marking out locations for each borehole
- setting up a safe work area with site specific environmental controls for each site
- traffic and pedestrian management to ensure the safety of motorists, residents and workers
- collecting borehole soil and rock samples.

A temporary worksite with safety fencing will be set up at the location to securely contain the drilling equipment.

Every effort will be made to minimise the impact of work, including by using non-tonal reversing beepers on all machinery, turning off equipment and vehicles when not in use and, where possible, directing noisy equipment away from residences. Access to residential properties will be maintained at all times. All worksites will also be restored to their previous condition.

If you would like further information, please call 1800 660 248 and ask to speak with a member of the M4-M5 Link project team or email [info@westconnex.com.au](mailto:info@westconnex.com.au).

## ABOUT WESTCONNEX

WestConnex is part of a broader transport plan for Sydney which includes improved public transport, such as Sydney Metro and light rail, as well as better, more reliable motorway solutions. More than two-thirds of WestConnex will be built underground. Once complete, motorists will be able to avoid up to 52 sets of traffic lights and enjoy significant travel time savings.

For more information

✉ [info@westconnex.com.au](mailto:info@westconnex.com.au)

☎ 1800 660 248

🌐 [westconnex.com.au](http://westconnex.com.au)



Easing  
congestion



Creating  
jobs



Connecting  
communities

## geotechnical investigations

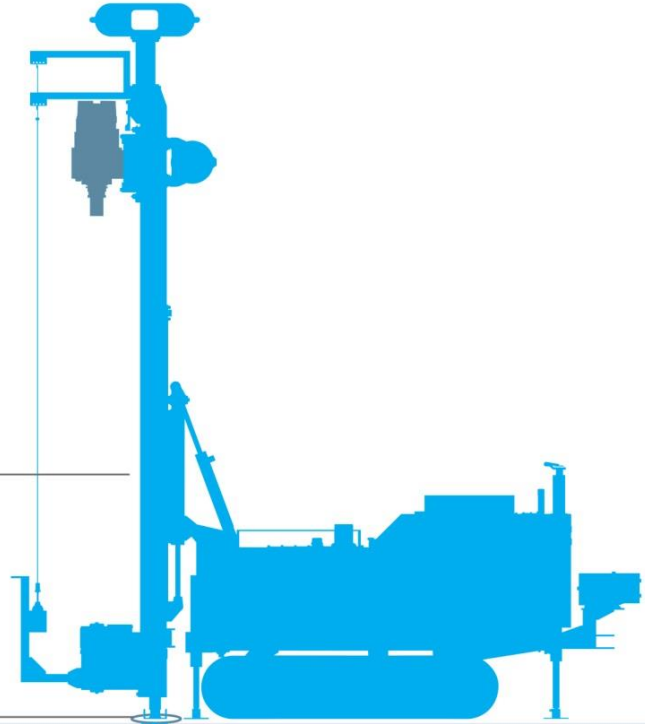

**Drilling rig** used to collect samples to produce a geological profile of the area. The rig size may vary depending on the ground condition and the drilling depth size.

**Small diameter boreholes** are created to take samples below ground.

**The rig can drill up to 45m below the ground.** The process can take around a week. On completion the area is restored to its original condition.



## We speak your language

### ENGLISH

To learn more, simply visit [westconnex.com.au/yourlanguage](http://westconnex.com.au/yourlanguage). Need an interpreter? Call the Translating and Interpreting Service on **131 450**.

### ARABIC

لمعرفة المزيد، ما عليك سوى زيارة [westconnex.com.au/yourlanguage](http://westconnex.com.au/yourlanguage). بحاجة إلى مترجم؟ اتصل بخدمة الترجمة الكتابية والترجمة الشفوية على الرقم **131450**.

### CHINESE

如需了解更多详情，请访问 [westconnex.com.au/yourlanguage](http://westconnex.com.au/yourlanguage)。如需翻译，请拨打翻译与口译热线 **131 450**。

### GREEK

Για να μάθετε περισσότερα, απλά επισκεφθείτε το [westconnex.com.au/yourlanguage](http://westconnex.com.au/yourlanguage). Χρειάζεστε διερμηνέα; Καλέστε την Υπηρεσία Μεταφραστών και Διερμηνέων στο **131 450**.

### HINDI

अधिक जानने के लिए केवल [westconnex.com.au/yourlanguage](http://westconnex.com.au/yourlanguage) पर देखें। क्या आपको दुभाषिण की ज़रूरत है? अनुवाद व दुभाषिया सेवा को **131 450** पर फ़ोन करें।

### ITALIAN

Per saperne di più, vai semplicemente al sito [westconnex.com.au/yourlanguage](http://westconnex.com.au/yourlanguage). Hai bisogno di un interprete? Chiama il servizio d'interpretazione e traduzione al numero **131 450**.

### KOREAN

더 자세히 알고 싶으시면, 바로 [westconnex.com.au/yourlanguage](http://westconnex.com.au/yourlanguage) 를 방문하시면 됩니다. 통역사가 필요하십니까? 번역 및 통역 서비스에 **131 450**으로 연락하십시오.

### VIETNAMESE

Để biết thêm, chỉ cần tới trang mạng [westconnex.com.au/yourlanguage](http://westconnex.com.au/yourlanguage). Cần thông dịch viên? Hãy điện thoại cho Dịch vụ Thông Phiên Dịch ở số **131 450**.